

FUNCTIONAL SERVICING &
STORMWATER MANAGEMENT REPORT

253 & 259 Limeridge Road West

MAY 9, 2023 (REVISED)

City of Hamilton



[THIS PAGE IS INTENTIONALLY LEFT BLANK]

TABLE OF CONTENTS

1.0 Introduction 1

 1.1 Background 1

 1.2 Site Location & Topography 1

 1.3 Proposed Development 1

2.0 Servicing Analysis 3

 2.1 Water Servicing..... 3

 2.2 Sanitary Servicing.....4

 2.3 Stormwater Management..... 5

 2.3.1 Existing Conditions 5

 2.3.2 Stormwater Criteria..... 5

 2.3.3 Stormwater Design 6

 2.4 Grading / Erosion & Sediment Control Considerations 7

3.0 Conclusions 8

Figures

Figure 1: Site Location Plan.....2

Tables

Table 1 – Hydrant Testing Data.....3

Table 2 – Table 2– Proposed Drainage Conditions, Summary.....6

Table 3 – Catchment P2, Proposed Drainage Conditions, Summary.....7

1. Introduction

1.1. Background

LandSmith Engineering & Consulting Ltd. have been retained by Qianye Property Management Ltd. for the completion of a *Functional Servicing Report* in support of the development of two properties located at 253 and 259 Limeridge Road West in the City of Hamilton. The purpose of this report is to illustrate how the development of these properties from single-family homes to the proposed 23 townhouse units and private road can be accommodated by the available municipal services adjacent to the site in accordance with the requirements of the City of Hamilton.

1.2. Site Location & Topography

The site is located to the south of Limeridge Road West between Garth Street and West 5th Street. Immediately to the south the site abuts the Lincoln Alexander Parkway while to the north, across Limeridge Road West are located Annunciation of our Lord Roman Catholic Church and School. To the east of the site there are two single family homes fronting Limeridge Road West, while at the rear there is a private townhouse condominium development. To the west the site abuts a walkway which crosses the Lincoln Alexander Parkway connecting to Fiona Crescent. Further to the west there is one single family home and then additional condominium developments. Figure 1 on the following page illustrates the exact location of the site.

A topographic survey illustrating the existing conditions of the lands has been included in Appendix 'A' for reference purposes. As can be seen through review of the survey, the front of the site generally slopes from south to north towards Limeridge Road West, with the portion sloping northerly increasing towards the east limit of the site. The rear of the property drains southerly towards the southwest corner of the site and into the adjacent walkway block. At the rear of the site there is a noise-barrier wall between the development parcel and the Lincoln Alexander Parkway (Linc). This barrier wall sits atop a steep slope which angles down to the travelled portion of the Linc. At the site frontage Limeridge Road West slopes gently from east to west.

1.3. Proposed Development

The current development proposal will entail the demolition of the two existing single family homes located on the property and the construction of a three blocks of townhouses fronting a private road. There is intended to be two 8-unit blocks and one 7-unit block for a total unit count of 23 townhouse units. As noted, these units will front a private roadway which connects to Limeridge Road West and terminates at the south limit of the site in a hammerhead.

There is proposed visitor parking at the south limit adjacent to the noted hammerhead and across from the 7-unit townhouse block. A *Site Plan* prepared by KNYMH Inc. which illustrates the proposed layout of the site is included in Appendix 'A' for reference purposes. This Site Plan was the basis of the following engineering analysis.



Figure 1: Site Location Plan

2. Servicing Analysis

2.1. Water Servicing

There is an existing 12" (300mm) diameter watermain located along the frontage of the site which may be utilized for the water servicing of the proposed development. This watermain is illustrated on plan 70-S-154 which is contained within Appendix 'D' for reference purposes.

Hydrant flow testing data for the hydrants nearest to the site was completed by the City of Hamilton in 2015. The results of this recent flow testing are contained within the table below.

Hydrant ID	Address	Pressure Zone	Test Date	Static Pressure (psi)	Residual Pressure (psi)	Test Flow (USGPM)	~Flow @ 20psi (USGPM)
HC49H001	280 Limeridge Rd W	6	16-07-2011	74	69	910	3289
HC53H023	190 Limeridge Rd W	6	16-07-2011	70	63	950	2747
HC53H024	219 Limeridge Rd W	6	16-07-2011	70	66	870	3403
HC53H025	250 Limeridge Rd W	6	16-07-2011	72	68	910	3636

Table 1: Hydrant Testing Data

This recent flow testing from 2011 indicates that there can be expected to be (at minimum) 273L/s (2747 USGPM) of available flow from the local 200mm watermain on Limeridge Road West for fire protection purposes at a system pressure of 20 psi.

The current City target for Fire-flow for multiple-residential units with greater than 3 units is the greater of 150 L/s, or the calculated Fire-flow demand based on the Ontario Building Code (Part 3).

The description of the OBC calculation for fire-flow is contained within Appendix 'B' for reference. As can be seen the calculation results a fire-flow requirement of 90 L/s. As such is the case, the greater amount of 150 L/s will be the development fire-flow criteria as per the City's target flow method.

In addition to fire-flow demands, domestic water demands were calculated using the fixture unit method and Table 7.6.3.2.A of the Ontario Building Code. The calculations are available within Appendix 'B' for reference. It was determined that the three proposed townhouse blocks will have 248.4 fixture units in use which is equivalent of a peak domestic flow rate of 6.06 L/s.

Based on the local hydrant testing and the provided OBC water demand calculations for fire and water we conclude that the local 300mm watermain can supply the required peak flow from domestic and fire demand of 156.06 L/s.

2.2. Sanitary Servicing

There is an existing 250mm sanitary sewer within Limeridge Road West which can provide sanitary service for the proposed development. This sanitary sewer is illustrated on drawing 70-S-154 which has been included in Appendix 'D' for reference purposes.

Calculations for the expected sanitary flows which will be generated from the proposed development area are described on the *Sanitary Drainage Area Plan* and associated *Sanitary Sewer Design Sheet* contained within Appendix 'B' for reference. As can be seen these calculations result in a design flow of 1.65 Lps based on the City of Hamilton sanitary design criteria and given the site density of 141 persons per hectare. (3 persons/unit x 23 units / 0.49 hectares)

Using the calculation method contained within the Ontario Building Code Table 8.2.1.3.A – Residential Occupancies, the expected sanitary sewer demand for the proposed development will be:

$23 \times 3 \text{ bedroom units} \times 3,200 \text{ L/day per } 3 \text{ bedroom unit} = 73,600 \text{ L/day} = 0.85 \text{ L/s.}$

The site sewers will be 200mm in diameter and this size will be adequate to service the proposed development.

As part of the comment received through the first submission of this report it was requested that the downstream sanitary system be analyzed to ensure that there is adequate capacity for the inclusion of additional flows from this development. As per the request of the City we have completed an analysis of the neighbourhood sanitary drainage from the site, downstream to the location that the local pipe discharges into a 525mm trunk sanitary pipe on Lynbrook Drive. This analysis is contained within Appendix 'B' and contains a neighbourhood area sanitary sewer design sheet together with a neighbourhood Sanitary Drainage Area Plan.

As can be seen, the flows from the proposed development can be accommodated within the existing system to the downstream confluence of pipes at the intersection of Limeridge Road West and Lynbrook Drive. Pipe data was obtained from City of Hamilton drawings, while the assumptions regarding the neighbourhood densities and expected sanitary generation are explained on the sanitary drainage area plan.

2.3. Stormwater Management

2.3.1. Existing Conditions

The topography of the site has been previously described in *Section 1.2*. As noted, in the pre-development condition the site drains both towards Limeridge Road (north-east areas) and towards the Lincoln Alexander Parkway (south-west areas). The limits of these drainage areas are described on the Pre-Development Drainage Area Plan contained within Appendix 'C' for reference purposes. The existing drainage area of the site the sewer within Limeridge Road West appears to have included runoff from the development at a runoff coefficient of $C=0.60$. This is indicated on plan 70-S-42 which has been included in Appendix 'D' for reference purposes. In addition, Figure S2 is provided within Appendix 'C' which attempts to illustrate that the entire site was considered at $C=0.60$ within the design of the sewer.

Notwithstanding the above, based on comments received from the City of Hamilton we understand that there is still uncertainty as to whether the entire site is included in the sewer design. In addition, based on the timing of the original design of the storm sewers it is not clear whether the Mount Hope IDF parameters were used, or whether other parameters could have been used resulting in lesser design flows from the site. We also note that there is significant stormwater management being provided on the school site across the road at 250 Limeridge Road West, however due to the fact that the City no longer has record of the approved report the discharge from this site to the local sewer is unknown.

Given the uncertainty of the design of the local storm sewer, and the difficulty in analyzing its existing performance given unknown stormwater controls on adjacent properties it was decided to limit the runoff from the site to only the area currently draining to Limeridge Road West, however with a runoff coefficient of $C=0.60$.

2.3.2. Stormwater Criteria

Quantity Target:

Given the description of the existing system as described in the previous section, the site should be limited to allow discharge only to the level of those areas currently draining to Limeridge Road West at a runoff coefficient of $C=0.60$. In addition, given Limeridge Road West is not a local road, the major overland flow from the site may not discharge onto the street. Therefore the 100-year event must be captured and released into the storm system without discharge from overland flow being released to the street. Based on these criteria, the maximum allowable release rate from the site is $0.034 \text{ m}^3/\text{s}$, to be released to the storm sewer (not over-land). A MIDUSS v2 calculation for the allowable release rate is contained within Appendix 'C' for reference purposes.

Quality Target:

The downstream receiver of the storm sewers is the Chedoke Falls / Chedoke Creek which discharges into Cootes Paradise and subsequently the Hamilton Harbour. As such is the case, Enhanced MECP Level 1 quality control is required for discharge from the site (80% long term TSS removal).

2.3.3. Stormwater Management Design

SWM Quantity Controls:

In order to limit runoff from the site and release it to the storm sewer at an equivalent rate of $C=0.60$ and area of 0.1947 Ha. for the site area an orifice control must be placed on the last downstream manhole. The location of this orifice is described on the Site Servicing Plan contained within Appendix 'A'. In addition, a super-pipe system must be constructed on the north-south leg of the site road to provide on-site storage for the runoff rates in excess of the allowable release rate.

All site runoff is to be captured and directed to the super-pipe – this can easily be achieved through the use of multiple inlets since the site is relatively small. Based on this design the proposed release rates from the site, storage volumes and water surface elevations are contained within the table below. As can be seen, the 100-year event water surface elevation is contained within the pipes.

Return Period (Yr.)	Peak Runoff Q (m ³ /s)	Peak Discharge (m ³ /s)	Used Storage Volume (m ³)	Water Surface Elev. (m)	% Allowable Discharge
5	0.089	0.019	65.3	222.56	55.9%
25	0.131	0.023	123.4	222.96	67.6%
100	0.165	0.033	161.58	223.39	97.0%

Table 2– Proposed Drainage Conditions, Summary

As can be seen, based on the proposed design the City of Hamilton’s stormwater quantity control criteria can be met and the peak-flows attributed to the adjacent storm sewer will be decreased below the allowable limit for every return period including the 100-year storm event.

Hydrologic and hydraulic analysis has been completed using MIDUSS v2 stormwater software, with Mount Hope IDF parameters. The orifice has been sized to 110mm and the output files displaying the routing of the superpipe system can be found in Appendix 'C' for reference.

SWM Quality Controls:

In addition to the stormwater quality controls identified in the previous section stormwater quality controls will also be required. The required MECP Level 1 'Enhanced' stormwater quality protection can be achieved through the use of an appropriately sized oil-grit separation unit together with CB Shield inserts to be placed in each of the proposed street catch-basins.

A sizing report for the required oil-grit separation unit has been included in Appendix 'C' for reference purposes – based on the sizing report a Stormceptor EF4 unit will be sufficient to provide 60% total suspended solids removal based on the ETV 'Fine' particle size distribution.

In addition to the OGS unit and in order to get an overall 'Enhanced' level of quality protection CB Shield inserts will also be required to be placed at each street CB inlet location on the site. A table describing the available level of protection from the CB Shield based on the percentage impervious of the site is contained within Appendix 'C' for reference. Based on the site % impervious of ~65% and the catchment size of less than 0.10 hectares to each CB the overall quality protection provided by the CB Shield is expected to be 53%.

Based on the above analysis the provision of the Stormceptor EF4 oil-grit separation chamber, together with the inclusion of the CB Shield at each street inlet will lead to the provision of the required 'Enhanced' level of stormwater quality control.

2.4. Grading / Erosion & Sediment Control Considerations

A brief summary of the site grading is provided here for reference purposes. The topography of the site was mentioned in Section 1.7. A preliminary Grading Plan has been included within Appendix 'A' for reference purposes. As can be seen, the major over-land flow route for the rear areas of the site cannot be directed to the street. Multiple inlets are provided at the western end of the west-east site road to ensure that all runoff is captured and directed to the stormwater super-pipe system.

A preliminary Sediment and Erosion Control (SEC) plan has also been prepared and included in Appendix 'A' for reference. Detailed SEC controls will be required to be implemented on site during and after construction until ground cover is established. A detailed 'for-construction' plan can be prepared for the site at the Site Plan stage.

3. Conclusions

In conclusion, based on the foregoing analysis we recommend that the development can be serviced in accordance with the requirements of the City of Hamilton as follows:

1. Water servicing can be provided through connection to the adjacent 200mm watermain along Limeridge Road West where indicated. There is ample water available for domestic usage and fire-flows based on the City of Hamilton hydrant flow test data.
2. There is an available sanitary sewer located on Limeridge Road West from which the proposed building can be serviced. The 250 mm diameter pipe has capacity to service the increased density due to the nature of the development. The downstream system has been analyzed to Lynbrook Drive and there is available capacity to accommodate the development.
3. Stormwater runoff from the site may be connected to the local municipal 450 mm storm sewer on Limeridge Road West. Quantity control will be provided through the construction of a super-pipe storage feature controlled by a 110mm orifice. Quality control will be provided through both the features of the construction of a Stormceptor EF4 oil grit separation unit together with CB Shield placement within the site catchbasins.

Thank you for your consideration of the above Functional Servicing Report, should you have any questions or require clarification with respect to any part of the above please do not hesitate to contact the undersigned.

Respectfully submitted,



Andrew Smith, P. Eng.
Principal & Director
LandSmith Engineering & Consulting Ltd.
289-309-3632
andrew@landsmithec.com



APPENDIX 'A' – Site Information

Topographic Survey – A.T. McLaren (2021)

Conceptual Site Plan – KNYMH Inc.

Typical Floor Plans – KNYMH Inc.

Building Elevations – KNYMH Inc.

Preliminary Engineering Plans - LandSmith

SURVEYOR'S REAL PROPERTY REPORT

PART 1, PLAN OF
LOTS 1, 2 & 3
REGISTERED PLAN 1008
IN THE
CITY OF HAMILTON

SCALE 1:200 METRIC
0 4 8 12 metres

R.A. McLAREN, O.L.S. - 2022

SURVEYOR'S REAL PROPERTY REPORT (PART 2)
LOTS 1, 2 & 3, REGISTERED PLAN 1008 AS ILLUSTRATED ON THE PLAN. THIS PLAN DOES NOT CERTIFY COMPLIANCE WITH ZONING BY-LAWS. THIS PLAN WAS PREPARED FOR LEI ZHAO

ASSOCIATION OF ONTARIO LAND SURVEYORS
PLAN SUBMISSION FORM
27312

THIS PLAN IS NOT VALID UNLESS IT IS AN EMBOSSED ORIGINAL COPY ISSUED BY THE SURVEYOR IN ACCORDANCE WITH REGULATION 1008, SECTION 22(5).

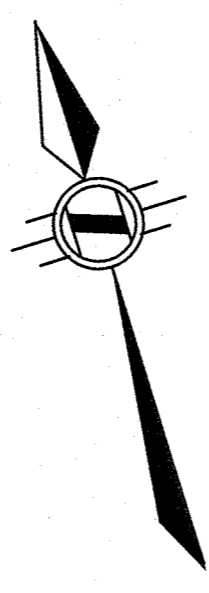

LIMERIDGE ROAD WEST
(ORIGINAL ROAD ALLOWANCE BETWEEN CONCESSIONS 6 & 7)

PIN 16967-0075 (LT)

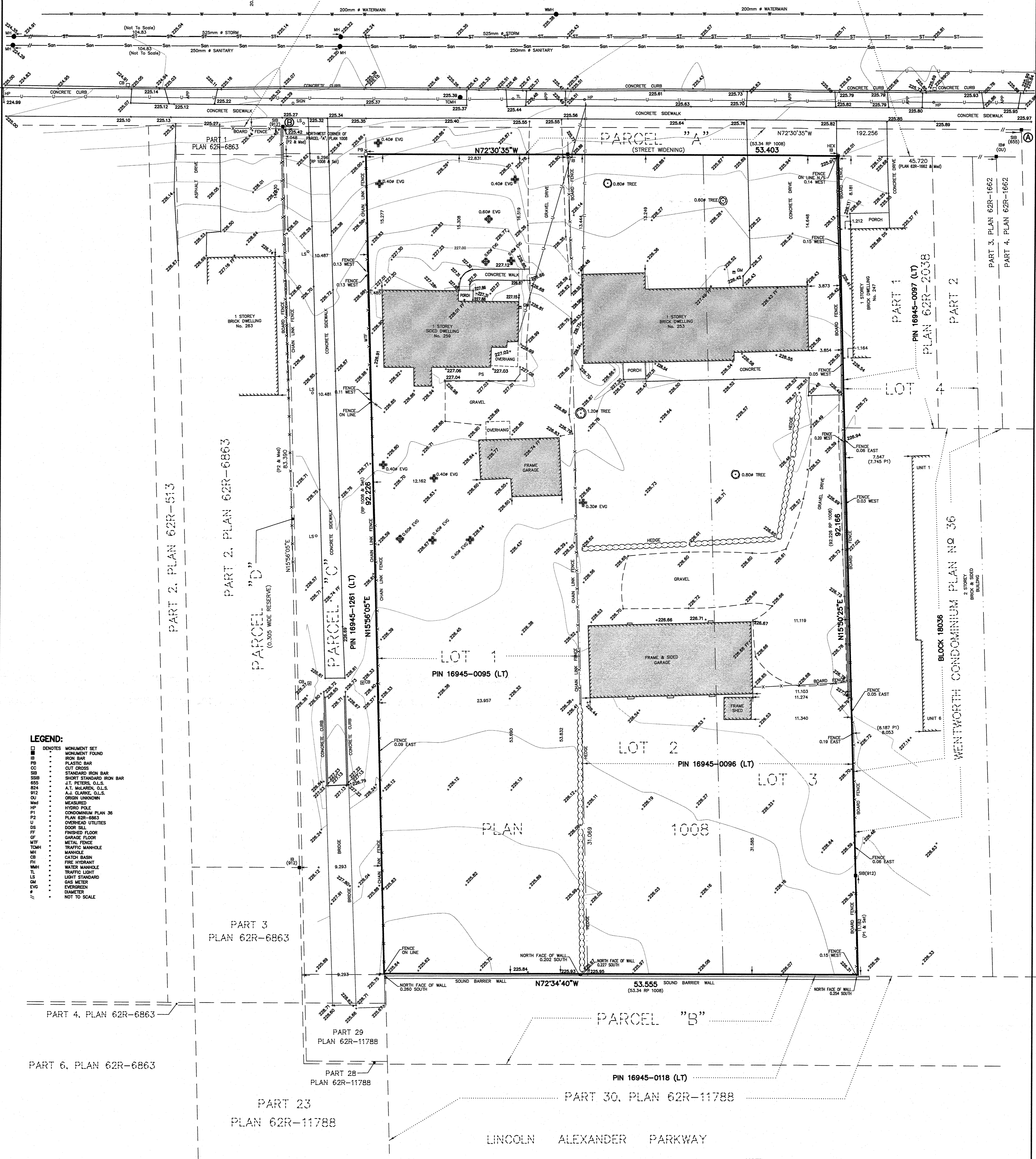

- LEGEND:**
- DENOTES MONUMENT SET
 - MONUMENT FOUND
 - IRON BAR
 - PLASTIC BAR
 - CUT CROSS
 - STANDARD IRON BAR
 - SHORT STANDARD IRON BAR
 - 655 J.T. PETERS, O.L.S.
 - 654 A.T. McLAREN, O.L.S.
 - 912 A.J. CLARKE, O.L.S.
 - GM GROUND UNKNOWN MEASURED
 - HP HYDRO POLE
 - P1 CONDOMINIUM PLAN 36
 - P2 PLAN 62R-6863
 - U OVERHEAD UTILITIES
 - DS DOOR SILL
 - FF FINISHED FLOOR
 - GF GARAGE FLOOR
 - MTF METAL FENCE
 - TMH TRAFFIC MANHOLE
 - MH MANHOLE
 - CB CATCH BASIN
 - FI FIRE HYDRANT
 - WM WATER MANHOLE
 - TL TRAFFIC LIGHT
 - LS LIGHT STANDARD
 - GM GAS METER
 - EVG EVERGREEN
 - DIAMETER
 - NOT TO SCALE

BEARING NOTE:
BEARINGS ARE UTM GRID, DERIVED FROM OBSERVED REFERENCE POINTS A AND B, BY REAL TIME NETWORK OBSERVATIONS, UTM ZONE 17, NAD83 (CSRS) (2010.0)

NOTE:
DISTANCES ARE GROUND AND CAN BE CONVERTED TO GRID BY MULTIPLYING BY THE COMBINED SCALE FACTOR OF 0.9996689

INTEGRATION DATA

POINT ID	NORTHING	EASTING
ORP @	4786294.436	189729.070
ORP @	4786152.587	588541.763

COORDINATES CANNOT, IN THEMSELVES, BE USED TO RE-ESTABLISH CORNERS OR BOUNDARIES SHOWN ON THIS PLAN.

BENCHMARK:
MONUMENT 0772090019
ROUND IRON BAR WITH BRASS CAP
17.15m NORTH OF THE CENTRELINE OF KENDALE COURT & 41.9m EAST OF THE SOUTHEAST CORNER OF APARTMENT BUILDING No. 21
ELEVATION: 225.436 metres COVD-1928-1978

METRIC NOTE:
DISTANCES AND COORDINATES SHOWN ON THIS PLAN ARE IN METRES AND CAN BE CONVERTED TO FEET BY DIVIDING BY 0.3048

SURVEYOR'S CERTIFICATE:
I, THE SURVEYOR, AND PLAN ARE CORRECT AND IN ACCORDANCE WITH THE SURVEYORS ACT AND THE REGULATIONS MADE UNDER THEM.
2. THE SURVEY WAS COMPLETED ON THE 28th DAY OF APRIL, 2022

25 MAY 22
DATE

R.A. McLAREN, O.L.S.

NOTE:
UNDERGROUND SERVICE AND UTILITY LOCATIONS WERE LOCATED BY CITY OF HAMILTON DRAWING No. 70-S-154 (SHEET 1 OF 1)
UNDERGROUND SERVICE AND UTILITY LOCATIONS MUST BE VERIFIED PRIOR TO CONSTRUCTION
INVERTS MUST BE VERIFIED PRIOR TO CONSTRUCTION

© R.A. McLAREN, O.L.S. - 2022. NO PERSON MAY COPY, REPRODUCE, DISTRIBUTE OR ALTER THIS PLAN IN WHOLE OR IN PART WITHOUT THE WRITTEN PERMISSION OF S.D. McLAREN, O.L.S.

A.T. McLaren Limited
LEGAL AND ENGINEERING SURVEYS
69 JOHN STREET SOUTH, SUITE 230
HAMILTON, ONTARIO, L8N 2B9
PHONE (905) 527-8559 FAX (905) 527-0032

Drawn: JB
Checked: DG
Cred. Chief: ZA
Scale: 1:200
Dwg. No. 36860



253 & 269 LIMERIDGE ROAD WEST



SITE PLAN STATISTICS
 LOT AREA = 4,928 sq.m
 LANDSCAPED AREA = 1,765 sq.m (35%)

NOTE:
 PRIVACY FENCE TO BE NOT LESS THAN 1.2m
 AND NOT MORE THAN 2.0m HIGH,
 WITH A LENGTH NOT LESS THAN 2.5m

CONTRACTOR MUST CHECK AND VERIFY ALL DIMENSIONS AND JOB CONDITIONS BEFORE PROCEEDING WITH WORK. ALL DRAWINGS AND SPECIFICATIONS ARE THE PROPERTY OF THE ARCHITECTS AND MUST BE RETURNED AT THE COMPLETION OF THE WORK.

THE CONTRACTOR WORKING FROM DRAWINGS NOT SPECIFICALLY MARKED FOR CONSTRUCTION MUST ASSUME FULL RESPONSIBILITY AND BEAR COSTS FOR ANY CORRECTIONS OR DAMAGES RESULTING FROM HIS OR HER WORK.

KEY TO DETAIL LOCATION

No.	DETAIL NUMBER
No.	DRAWING SHEET NUMBER

PRINTS ISSUED	No.	DATE (DD,MM,YY)	BY
PLANNING REVIEW	1	21-04-03	-

ALL PREVIOUS ISSUES OF THIS DRAWING ARE SUPERSEDED

REVISIONS TO DRAWING	No.	DATE (DD,MM,YY)	BY

NOT FOR CONSTRUCTION

BUILDING PERMIT NUMBER:
 NOT FOR CONSTRUCTION WITHOUT PERMIT

KNYMH
 ARCHITECTURE SOLUTIONS

3190 HARVESTER ROAD • SUITE 202
 BURLINGTON, ONTARIO • L7N3T1
 T 905.639.6595
 F 905.639.0394

www.knymh.com info@knymh.com

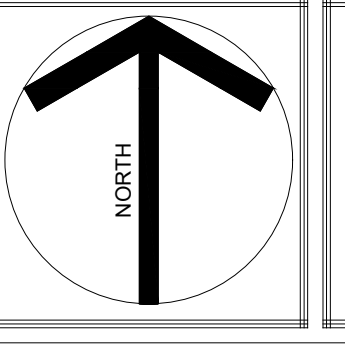

PRELIMINARY

TOWNHOUSE DEVELOPMENT
 253 & 259 LIMERIDGE ROAD WEST
 HAMILTON, ONTARIO

DRAWING SHEET TITLE:
SITE CONCEPT

DRAWING SCALE: 1:200
 MH PROJECT NUMBER: **22048**

DRAWN BY: -
 DRAWING SHEET NUMBER:

ISSUED DATE: Issue Date
 PLOT DATE: April 3, 2023
SP1

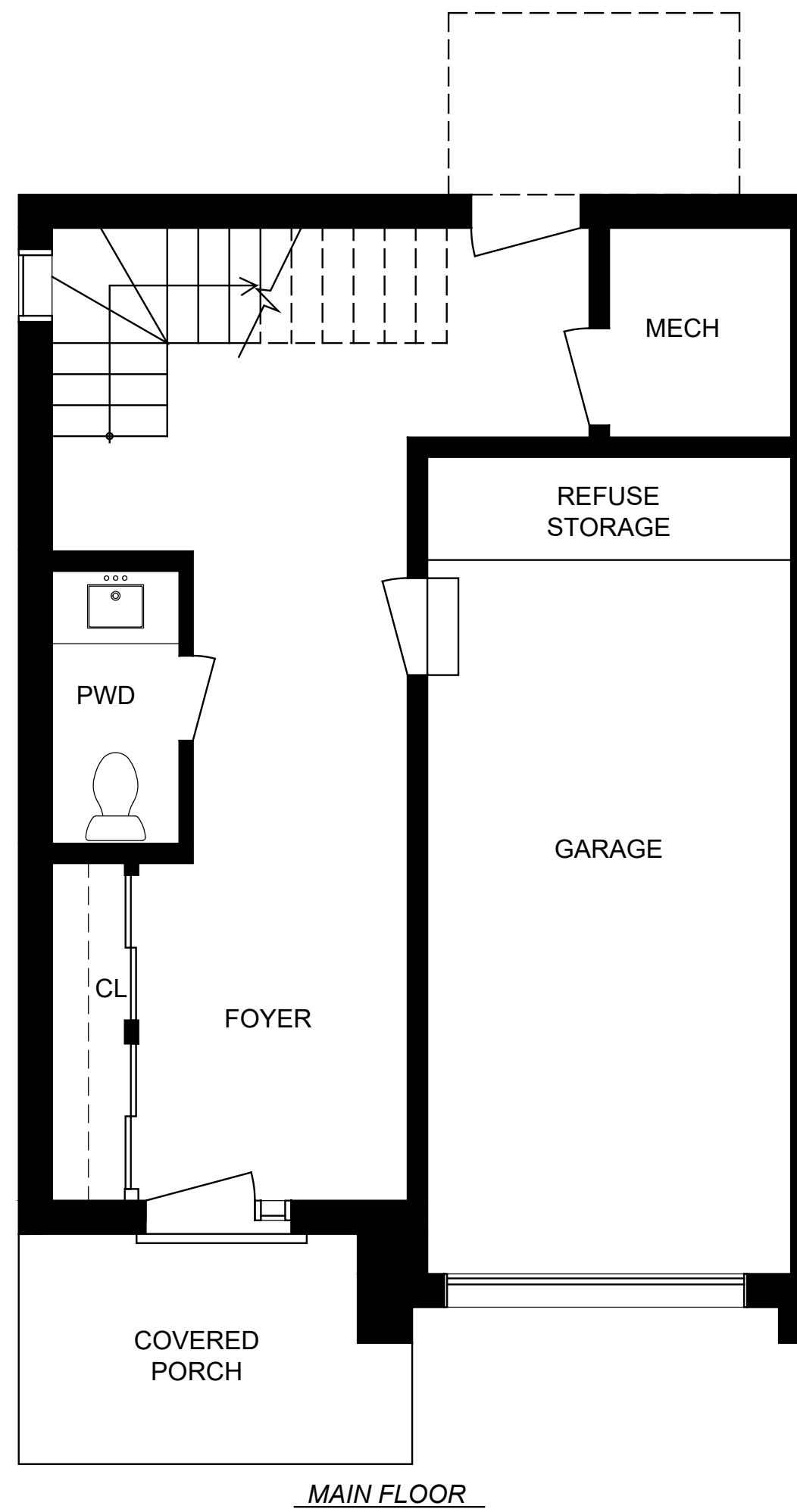

MAIN FLOOR

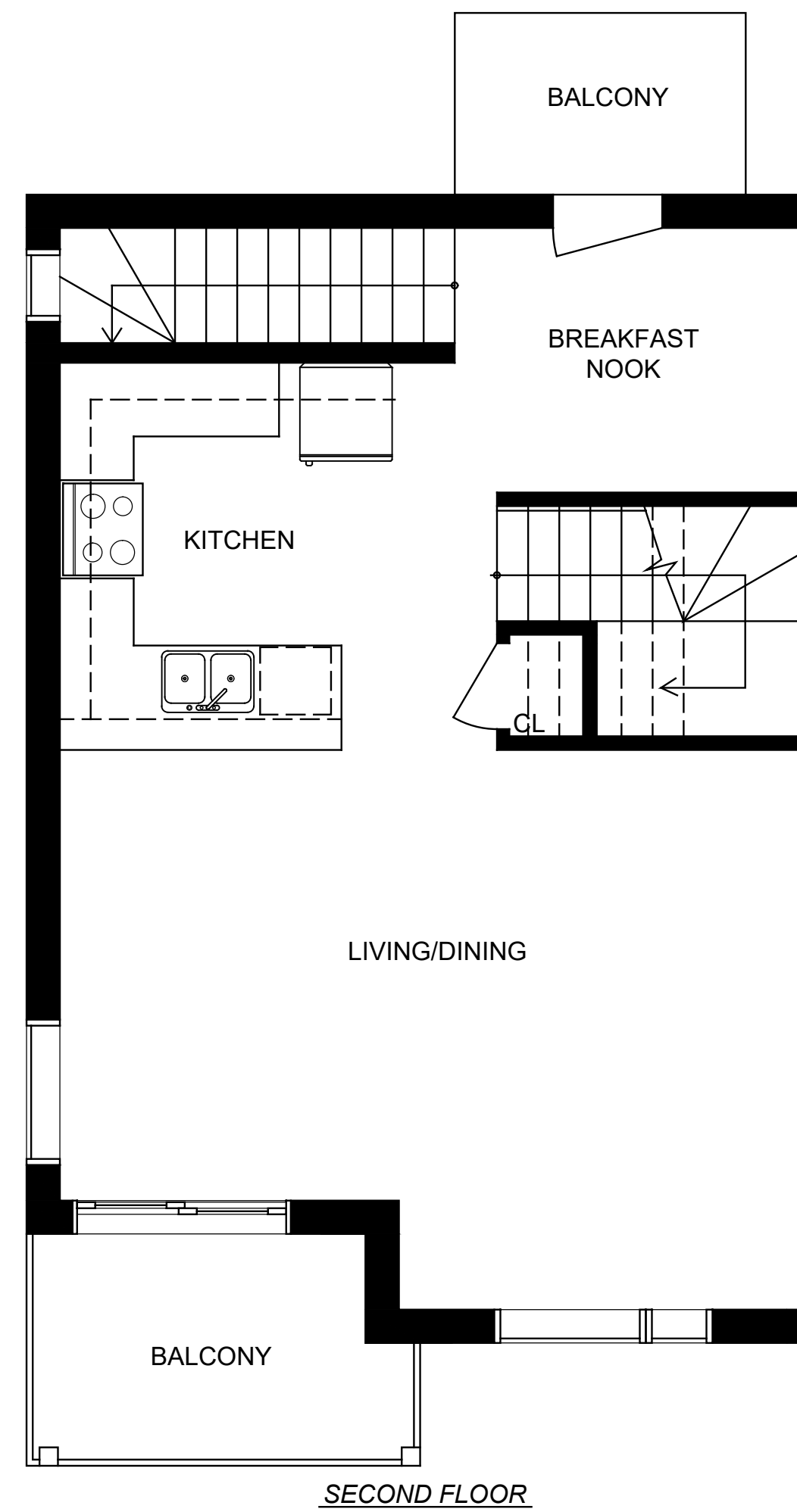

SECOND FLOOR

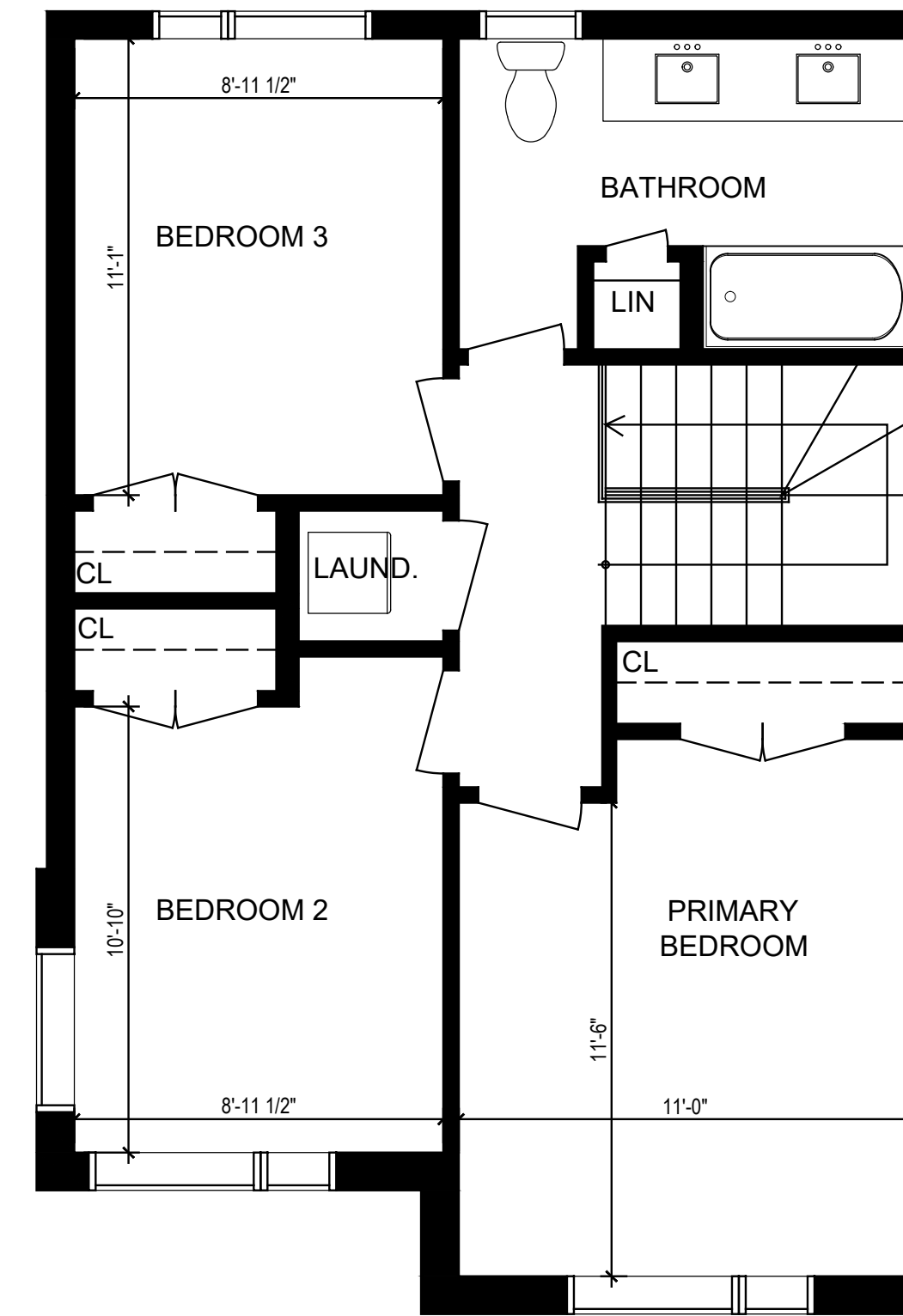

THIRD FLOOR

2 TYPICAL END UNIT
A1.00 1/4" = 1'-0"

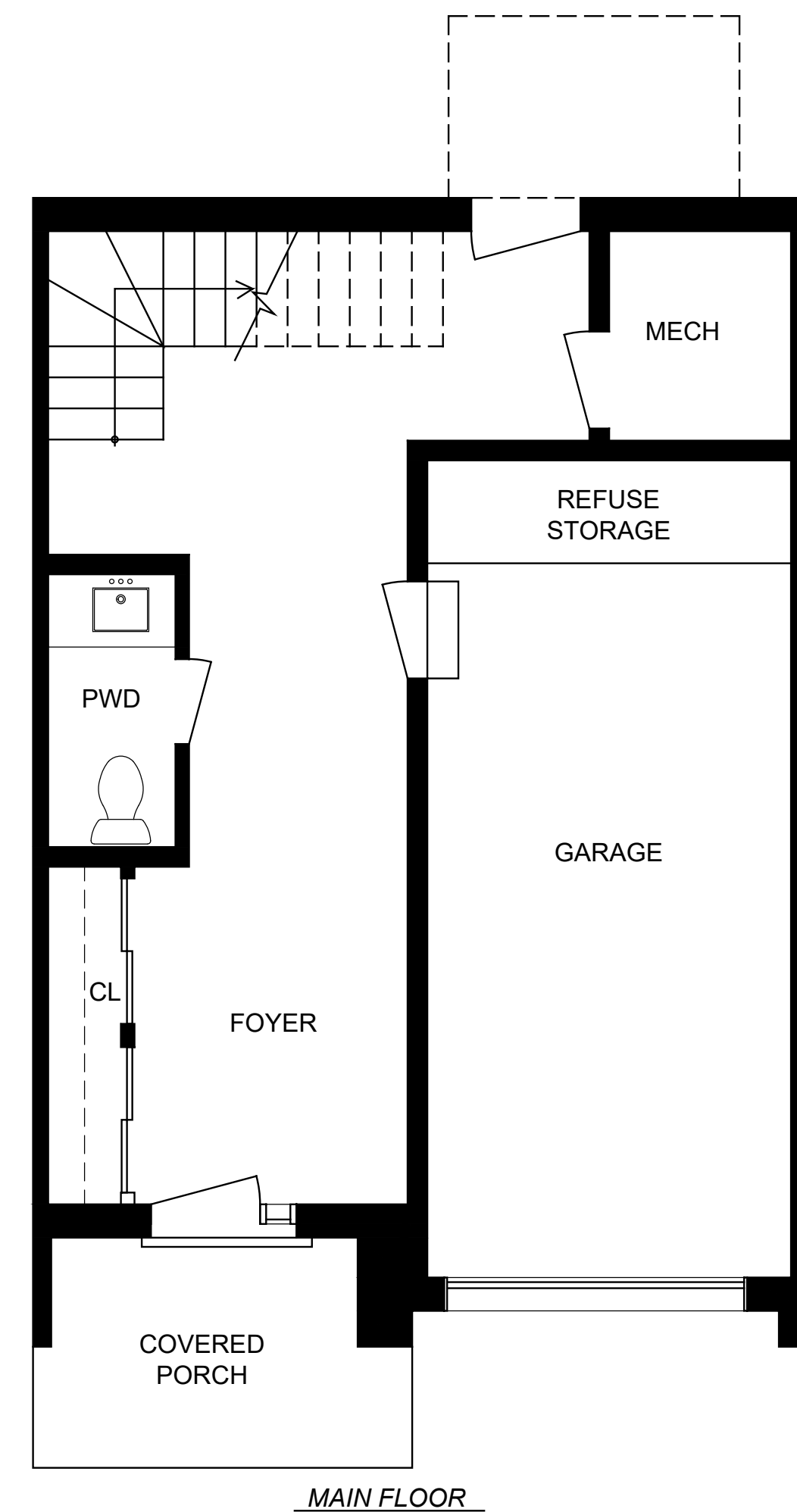

MAIN FLOOR

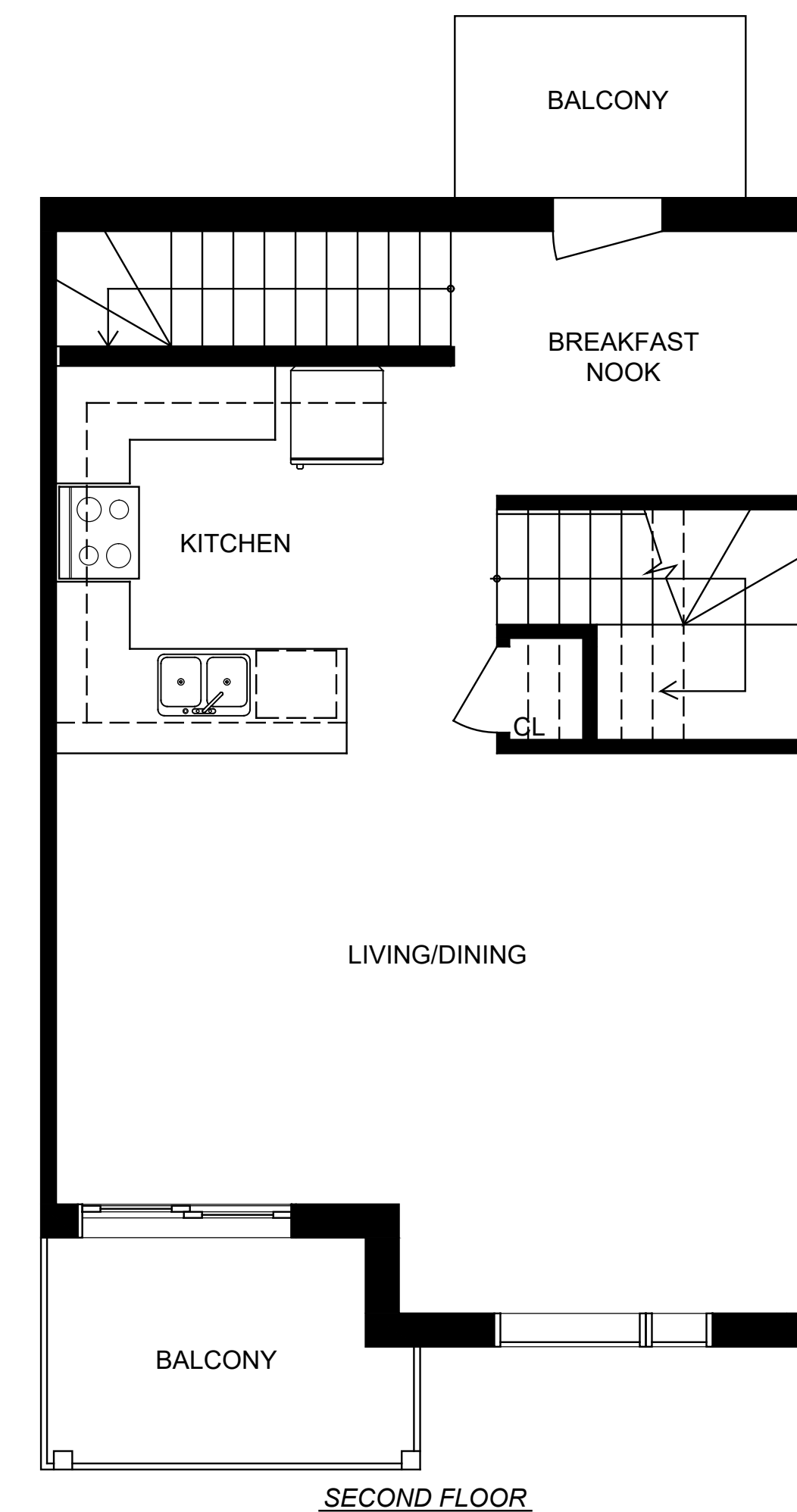

SECOND FLOOR

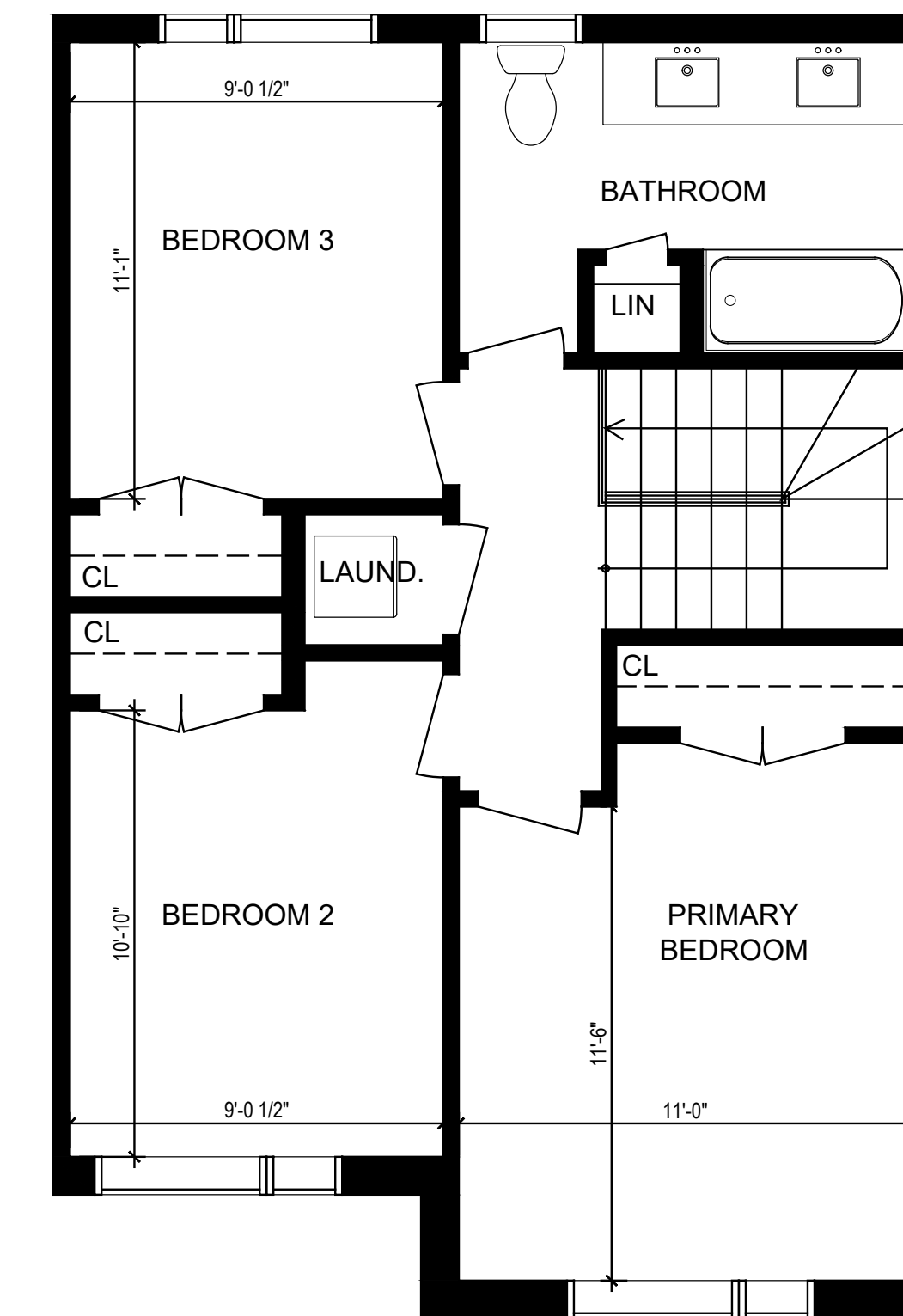

THIRD FLOOR

1 TYPICAL INTERIOR UNIT
A1.00 1/4" = 1'-0"

CONTRACTOR MUST CHECK AND VERIFY ALL DIMENSIONS AND JOB CONDITIONS BEFORE PROCEEDING WITH WORK
ALL DRAWINGS AND SPECIFICATIONS ARE THE PROPERTY OF THE ARCHITECTS AND MUST BE RETURNED AT THE COMPLETION OF THE WORK
THE CONTRACTOR WORKING FROM DRAWINGS NOT SPECIFICALLY MARKED FOR CONSTRUCTION MUST ASSUME FULL RESPONSIBILITY AND BEAR COSTS FOR ANY CORRECTIONS OR DAMAGES RESULTING FROM HIS OR HER WORK.

KEY TO DETAIL LOCATION

No.	DETAIL NUMBER
No.	DRAWING SHEET NUMBER

PRINTS ISSUED	No.	DATE (DD,MM,YY)	BY

ALL PREVIOUS ISSUES OF THIS DRAWING ARE SUPERSEDED

REVISIONS TO DRAWING	No.	DATE (DD,MM,YY)	BY

NOT FOR CONSTRUCTION

BUILDING PERMIT NUMBER:
NOT FOR CONSTRUCTION WITHOUT PERMIT

KNYMH
ARCHITECTURE
SOLUTIONS

3190 HARVESTER ROAD • SUITE 202
BURLINGTON, ONTARIO • L7N3T1
T 905.639.6595
F 905.639.0394

www.knymh.com info@knymh.com

PRELIMINARY

TOWNHOUSE DEVELOPMENT
253 & 259 LIMERDIDGE ROAD WEST
HAMILTON, ONTARIO

DRAWING SHEET TITLE:
CONCEPT FLOOR PLANS

DRAWING SCALE: 1/4" = 1'-0"	MH PROJECT NUMBER: 22048
DRAWN BY: --	DRAWING SHEET NUMBER: A1.00
ISSUED DATE: Issue Date	
PLOT DATE: November 22, 2022	

MATERIALS LEGEND

[Pattern]	BRICK - DARK
[Pattern]	BRICK - LIGHT
[Pattern]	STONE - DARK
[Pattern]	STONE - LIGHT
[Pattern]	NYL. SING. - DARK
[Pattern]	WOOD SING. - WOOD
[Pattern]	TRIM - DARK
[Pattern]	TRIM - LIGHT
[Pattern]	ASPHALT SHINGLES
[Pattern]	GLAZING

KEY TO DETAIL LOCATION

CONTRACTOR MUST CHECK AND VERIFY ALL DIMENSIONS AND JOB CONDITIONS BEFORE PROCEEDING WITH WORK. ALL DRAWINGS AND SPECIFICATIONS ARE THE PROPERTY OF THE ARCHITECTS AND MUST BE RETURNED AT THE COMPLETION OF THE WORK.

THE CONTRACTOR WORKING FROM DRAWINGS NOT SPECIFICALLY IDENTIFIED AS SUCH SHALL BE RESPONSIBLE FOR ANY CORRECTIONS OR DAMAGES RESULTING FROM HIS OR HER WORK.

NO. DETAIL NUMBER
NO. DRAWING SHEET NUMBER

PRINTS ISSUED No. (DD.MM.YY) BY

DATE (DD.MM.YY)

ALL PREVIOUS ISSUES OF THIS DRAWING ARE SUPERSEDED.

REVISIONS TO DRAWING No. (DD.MM.YY) BY

DATE (DD.MM.YY)

NOT FOR CONSTRUCTION

BUILDING PERMIT NUMBER

NOT FOR CONSTRUCTION WITHOUT PERMIT

KINYMIF
ARCHITECTURE SOLUTIONS

3190 HARVESTER ROAD • SUITE 202
BURLINGTON, ONTARIO • L7N 6T1
T 905.639.6555
F 905.639.0394
info@kinymif.com
www.kinymif.com

PRELIMINARY

TOWNHOUSE DEVELOPMENT

253 & 259 LIMERIDGE ROAD WEST
HAMILTON, ONTARIO

CONCEPT ELEVATIONS
BUILDING C
PARTIAL NORTH

DRAWING SCALE: 1/4" = 1'-0"
PROJECT NUMBER: 22048

DRAWING SHEET NUMBER: A2.01
ISSUED DATE: Issue Date
PLOT DATE: December 13, 2022

BUILDING 7 FRONT (NORTH)
8 UNIT TOWNHOUSE



BUILDING C

253-259 LIMERIDGE ROAD WEST



KEY PLAN **N.T.S.**

BENCHMARK NOTE:
 ELEVATION = 225.38
 MONUMENT: CUT-CROSS

BENCHMARK NOTE:
 STATION: 007720091809

WEST FACE OF HOUSE NO. 355 LIMERIDGE ROAD LOCATED APPROXIMATELY 90m EAST OF THE LOT LINE BETWEEN WELLINGTON AND WENTWORTH STREETS. PLACQUE IS SET 1m NORTH IN SECOND FROM THE TOP CONCRETE BLOCK OF THE SOUTHWEST CORNER OF THE HOUSE.

NO. 967 ELEVATION 207.201

GENERAL NOTES:

1. TENDERER SHALL SATISFY THEMSELVES AS TO THE NATURE OF THE GROUND AND BID ACCORDINGLY.
2. ALL ROCK LINE INDICATIONS SHOWN ON THE PLAN MUST BE VERIFIED BY THE CONTRACTOR.
3. CONTRACTOR SHALL VERIFY LOCATIONS AND INVERTS OF ALL EXISTING SANITARY AND STORM SEWERS AND WATERMAINS, PRIVATE DRAINS AND WATER SERVICES, GAS MAINS, CABLE TV, HYDRO AND TELEPHONE DUCTS ETC AT START OF CONSTRUCTION.

NO.	DATE	DESCRIPTION

NO.	DATE	DESCRIPTION
1	2023-05-09	REVISED PER CITY 1ST ROUND COMMENTS
0	2022-12-16	FIRST SUBMISSION

REVISIONS		
NO.	DATE	DESCRIPTION

SEAL

LANDSMITH ENGINEERING & CONSULTING LTD.
 UNIT 207, 1065 UPPER JAMES ST.
 HAMILTON, ON L9C 3A6
 ANDREW@LANDSMITHEC.COM
 289-309-3632

CLIENT:
 QIANYE PROPERTY MANAGEMENT LIMITED

MUNICIPALITY:
 CITY OF HAMILTON

PROJECT NAME:
 253-259 LIMERIDGE ROAD WEST

TITLE:
 NOTES

SCALE: N/A	DATE: 2023-05-09
CHECKED BY: AS	DESIGNED BY: AS
DWG No: 22050QIA	SHEET No: 01

STANDARD NOTES

A - SEWERS

1. Sanitary and Storm Sewers
 - a) Construction of sanitary & storm sewers & private drains shall be in accordance with City Standards & Specifications (late6t edition) and Ministry of Environment (MOE) Guidelines (latest edition).
 - b) Cover and bedding material for concrete pipe shall be Granular 'A' material a6 per OPSD 802.030 or 802.033, Class 'B' bedding.
 - c) Cover and bedding material for PVC pipe shall be Granular 'A' material as per OPSD 802.010 or 802.013.
 - d) PVC pipe will require special construction procedures as per City Specifications.
 - e) All sewers to be flushed prior to video inspection.
 - f) Manhole frames and covers shall be ae per OPSD 401.010 (Storm-open, Sanitary-closed).
 - g) Sanitary sewer (200mm to 375mm dia.) shall be PVC pipe, CSA B182.2, SDR-35.
 - h) Storm sewer (300mm to 375mm dia.) shall be PVC pipe, CSA B182.2, SDR-35.
 - i) Storm sewer > 375mm dia. shall be concrete pipe, CSA A257.2 (as specified)
 - j) PVC (sanitary and storm) sewers are to be tested for deflection (mandrel passage) after installation. Sanitary sewers shall also be tested for leakage (low air pressure). Prior to assumption by the City, pipe deflection testing shall be repeated.
 - k) Alternate materials may be acceptable provided approval has first been obtained from the City/Engineer.

2. Private Drains

- a) 'S' denotes single sanitary private drain connection. 'D' denotes dual private drain connection (sanitary & storm).
- b) To be located 1.5m on right side of centreline of lot or as detailed and extended 1.0m beyond the street line. The storm service shall be installed to the north or east of the sanitary service.
- c) Private drains to be 150mm dia. PVC pipe, csab182 1m-1983, sdr28 as per FORM 500. Storm pipe shall be white and sanitary shall be any colour other than white. Wood marking at end of sanitary private drain shall be painted red.
- d) Cover and bedding material for private drains shall be Granular 'A' installed as per OPSD 802.010 or 802.013.
- e) Minimum fall for private drains to be 2.0%.
- f) Top of sanitary private drains at street line to be 2.2m (min.) below centreline road elevation at that point or as detailed.
- g) Top of storm private drains at street line to be 1.2m (min.) below centreline road elevation at that point or ae detailed.
- h) Building rainwater leaders shall not be connected to the storm private drain but shall discharge onto the ground surface via splash pads.
- i) Sump pumps with check valves shall be installed in each dwelling to pump the building weeping tiles to the storm private drains. The sump outlet pipe shall extend a minimum of 150mm above the propO60d grade at the dwelling (basement ceiling) prior to discharging to the storm private drain.

B - WATERMAINS AND WATER SERVICES

1. Watermains

- a) Construction of watermains & private services shall be in accordance with City Standards & Specifications (latest edition) and Ministry of Environment (MOE) Guidelines (latest edition).
- b) To be installed to a minimum depth of 2.1m below proposed centreline road grade on all roads except on (N/A) where the minimum depth is 1.6m.
- c) PVC pipe in sizes 100mm through 300mm shall be Class 150 DR18 conforming to AWWA C900.
- d) Tracer wire shall be installed with PVC pipe in accordance with RHW FORM 1800. It shall be 12 gauge TW75, TWU75 or RW90XLPE coated copper and shall be positioned along the top of the pipe and fastened at 6 metre intervals. The wire is to be installed between each valve and/or the end of the new PVC watermain. Joints in the wire between valves are not permitted. At each gate valve a loop wire is to be brought up inside the valve box to the cap. The tracer wire shall be brought to the surface at the secondary valve on all fire hydrants. The tracer wire shall also be connected to the cathodic protection system as required.
- e) Molded PVC fittings for pipe sizes 100mm to 300mm shall conform to AWWA C900 and certified to CSA B137.2.
- f) Fabricated fittings 250mm and 300mm shall be manufactured from segments of AWWA C900, Class 150 (DR18) PVC pipe, bonded together and over-wrapped with fibreglass-reinforced polyester to meet the requirements of CSA B137.3.
- g) Where metal fittings are to be used on PVC mains sufficient cathodic protection must be provided as per the following requirement:
- i. Minimum of one 11kg zinc anode shall be installed for every 1000m of tracer wire;
- ii. One 11kg zinc anode shall be installed for each copper water service connection;
- iii. One 11kg zinc anode shall be installed on every valve, hydrant, bend, tee, sleeve, reducer, plug, cap, joint restraint, coupling, ect., connected to the PVC pipe.
- h) Bedding and backfill as per RWS.500 Granular 'A' material for mains and services greater than 50mm.
- i) Watermain deflection for PVC pipe:
 - i. Maximum allowable deflection of 1.5 degrees per joint up to 250mm diameter (160mm per 6.1m pipe length) and 1.2 degrees for 300mm diameter (128mm per 6.1m pipe length) shall not be exceeded.
 - ii. All joints shall be deflected an equal amount.
- j) All fittings and valves shall be restrained for 3 full pipe lengths (up to 18m) in each direction. All fittings at dead ends shall be restrained for 3 full pipe lengths (up to 18m). All sections of watermain installed in fill areas, are to be mechanically restrained at all joints.

2. Flushing, swabbing, and testing

- a) All new watermains are to be swabbed in accordance with City specification.
- b) A reduced pressure zone Backflow Preventer (WATTS SERIES 909 or approved equal) ie. Required on the temporary supply lines used for filling and flushing or swabbing watermains.
- c) Upon completion of installation, the Contractor shall perform a pressure test on the watermains as per FORM 400. Watermain is to be tested prior to connection rto existing watermains using temporary caps or plugs. Pipe closures, where required, are to be supplied by the Contractor. The Contractor will also supply and install all adaptor pieces in order to connect to existing watermains.

3. Water Services

- a) 'W' denotes water service connection (25mm dia. Type 'K' soft copper) as per WM-207.01 or as detailed.
- b) To be located 1.0m on left side of centre line of lot opposite sanitary private drain or as detailed, with curb stop adjacent to the streetline.
- c) Granular bedding as per WM-200.01 and WM-200.02 to be Granular 'D' as per FORM 600.

4. Valves & Valve Boxes

- a) All valve boxes to be set to proposed grades.
- b) 100mm to 300mm gate valve & valve boxes as per WM-202.

5. Anchor Blocks

- a) For 100mm to 300mm watermains standard concrete anchor blocks as per WM-204.01.

6. Hydrants

- a) To be installed with secondary valves as per WM-203.01 or WM-203.02 as detailed. They shall open counterclockwise (left) and have a 'L' painted on the barrel section. The 100mm pumper 'Storz' connection shall face the roadway and be painted black.
- b) All fire hydrants shall conform to the City of Hamilton (municipality) Fire Department's requirements and shall be of same manufacture.

C - ROADWORKS

1. General

- a) Construction of roadways & related works shall be in accordance with City Standards and Specifications (latest edition).
- b) Following the installation of sewers, all roadways shall be rough graded to subgrade for the installation of watermains & utilities.

2. Preliminary roads

- a) No preliminary roads to be installed

3. Catch Basins

- a) Catch basin connections to be 250mm dia. PVC pipe CSA B182.2, SDR-35 unless otherwise noted.
- b) Single/double street CdIGH basins as per OPSD 705.010/705.020 respectively with goss traps SEW-304.
- c) Private rear yard catch basins as per OPSD 705.010 (no goss traps).
- d) Street CB grates as per OPSD 400.020 (flat) and rear yard CB grates to be beehive type grate and cover as per AJC Dwg. SK-15.

4. Final Roadways

- a) Cross-fall to be 2.0%.
- b) Standard deep strength pavement (40mm HM 3, 80mm HL 8 on 150mm Granular 'A' & 300mm Granular 'B', Type II 100% crushed aggregate) for typical urban residential streets (TERRYBERRY ROAD, DALGLEISH TRAIL (REGIONAL ROAD NO. 56 TO TERRYBERRY ROAD) typical pavement profile shall be 40mm HM 3, 100mm HL 8 on 150mm Granular 'A' & 300mm Granular 'B', Type II 100% crushed aggregate.
- d) Manholes and catch basin top adjustments, all permanent adjustments are to be poured in place.
- e) Final asphalt course (HM 3) shall be placed a min. of one year after the installation of the asphalt binder course.

5. Sidewalks, Curbs & Gutters

- a) Concrete curb and gutter ae per OPSD 600.040 - (barrier type), min. 30 MPa strength. A 50mm key is required for all locations.
- b) Curb depression at driveways as per OPSD 600.040 and OPSD 310-050.
- c) 1.5m wide concrete sidewalk as per Hamilton Standard Drawing RD-103 (125mm thickness, min. 30 MPa strength with Granular 'A' base as required to provide a levelling course for the concrete. At driveways, concrete depth to be min. 125mm.
- d) Wheelchair ramps required at all intersections as per Hamilton Standard Drawing RD-124.01.
- e) Asphalt ramping shall be placed to suit the wheelchair ramps if surface course asphalt is not installed at the same time. These ramps are to be removed just prior to placement of surface course asphalt.

6. Driveways

- a) Maximum driveway grades shall be 7 percent.
- b) Driveway aprons shall be 50mm HL3, 75mm HL8 on 150mm Gran. A as per Hamilton Standard Drawing RD-108.

7. Road subdrains

- a) 100mm filter wrapped corrugated subdrains to be installed continuously below the curb and gutter and connected to the CB's.

D - COMPACTION REQUIREMENTS

- a) All bedding and backfill material, road sub-grades and generally all material used for lot grading and fill sections, etc., shall be compacted to min. 100% SPD (unless otherwise recommended by the geotechnical engineer). All material shall be placed in layers not exceeding 300mm lifts.
- b) All granular road base materials shall be compacted to 100% SPD.
- c) For all sewers and watermains in fill sections, the compaction shall be certified by a geotechnical engineer prior to laying of pipe.

E - SILTATION AND EROSION CONTROL

- a) Siltation control barriers shall be placed as detailed.
- b) All erosion and sediment controls shall be inspected weekly in addition to inspection after each rainfall event to the satisfaction of the City of Hamilton.
- c) Additional silt control locations may be required as determined by the City of Hamilton.

LIMERIDGE ROAD WEST

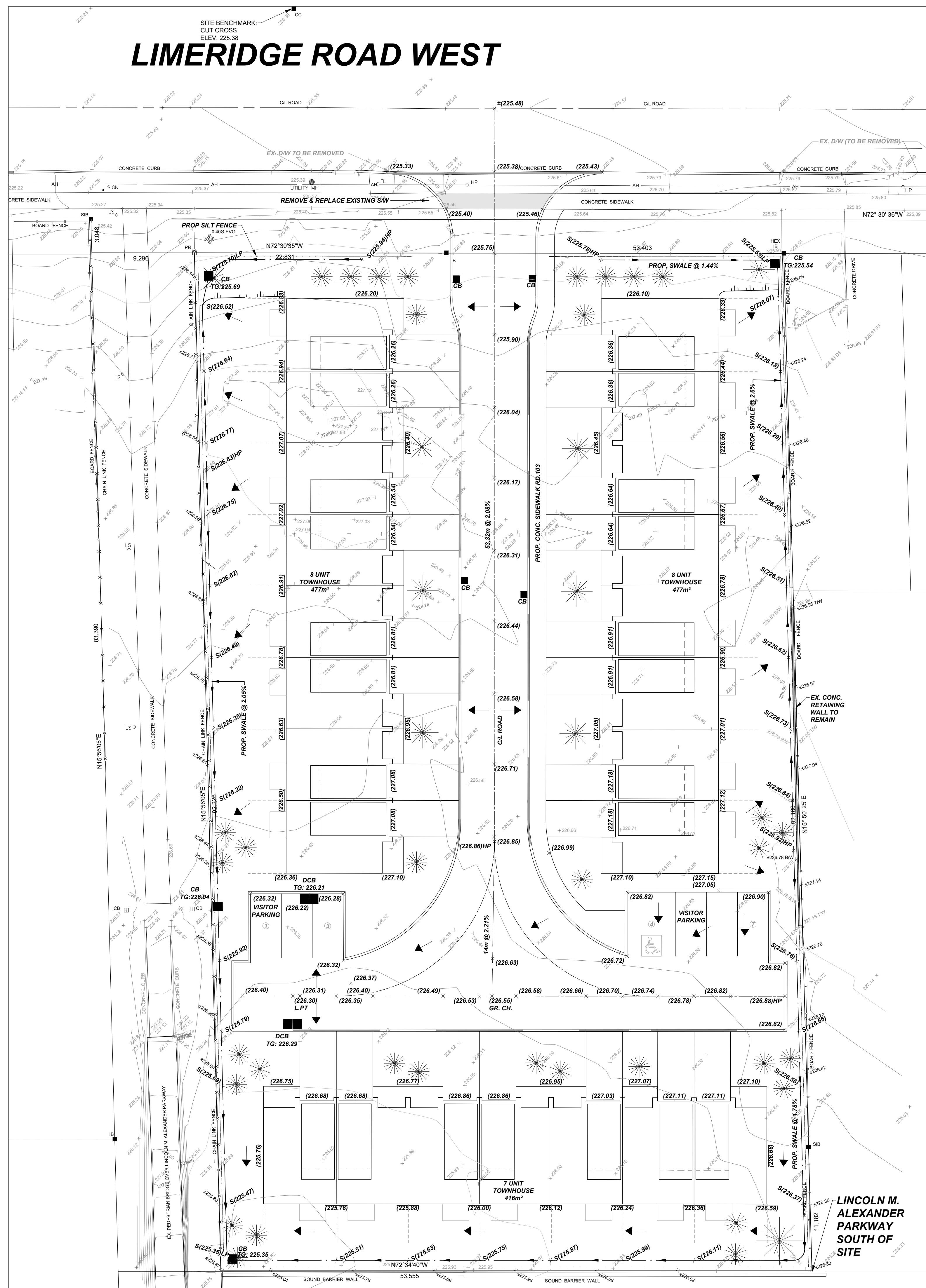

LINCOLN M. ALEXANDER PARKWAY SOUTH OF SITE



KEY PLAN N.T.S.

BENCHMARK NOTE:
ELEVATION = 225.38
MONUMENT: CUT-CROSS NORTH OF SITE

BENCHMARK NOTE:
STATION: 00720081809
WEST FACE OF HOUSE NO. 355 LIMERIDGE ROAD LOCATED APPROXIMATELY 90m EAST OF THE LOT LINE BETWEEN WELLINGTON AND WENTWORTH STREETS. PLAQUE IS SET 1m NORTH IN SECOND FROM THE TOP CONCRETE BLOCK OF THE SOUTHWEST CORNER OF THE HOUSE.
NO. 967 ELEVATION 207.201

LEGEND	
× 100.50	EXISTING ELEVATION
○ ±100.50	EXISTING ELEVATION (CALCULATED)
× (100.00)	PROPOSED ELEVATION
○ (100.00)	PROPOSED APRON ELEVATION
× S(100.00)	PROPOSED SWALE ELEVATION
○	PROPOSED DOWNSPOUT
▲	PROPOSED ENTRANCE LOCATION
—	PROPOSED SWALE
—	PROPOSED SWALE WITH SUBDRAIN
—	PROPOSED SILT FENCE

- GENERAL GRADING NOTES:**
- MATCH EXISTING GRADE AT PROPERTY / DEVELOPMENT LIMITS WITH SODDED SLOPES OF MAXIMUM 3:1 AND/OR RETAINING WALLS AS SPECIFIED.
 - SLOPES OF SWALES FOR BOTH "BACK-TO-FRONT" AND "SPLIT" DRAINAGE SHALL BE NO LESS THAN 2.0% AND NO GREATER THAN 3% (3:1).
 - MINIMUM GRADE FOR APRON "WRAP-AROUND" SWALE AT THE REAR OF THE UNIT SHALL BE 1.0%.
 - WHEN MATCHING TO EXISTING GRADE AT THE LIMITS OF THE DEVELOPMENT / PROPERTY WHERE 2.0% SLOPE CANNOT BE REASONABLY ACHIEVED A 1.5% GRADE IS PERMITTED PROVIDED A 150MM SUB-DRAIN IS INSTALLED WITH THE SWALE AS PER RD-121 AND CONNECTED TO A SUITABLE OUTLET.
 - DRIVEWAY SLOPES SHALL NOT BE LESS THAN 2.0% AND SHALL NOT BE MORE THAN 7.0%. REVERSED SLOPED DRIVEWAYS ARE NOT ALLOWED FOR ANY NEW CONSTRUCTION.
 - GARAGE FLOOR ELEVATION SHALL BE SET A MINIMUM OF 0.30M HIGHER THAN THE BACK OF WALK, UNLESS OTHERWISE SPECIFIED.
 - THE TOP OF FOUNDATION WALL FOR THE DWELLING UNIT SHALL BE A MINIMUM 150MM (6") ABOVE FINISHED GRADE.
 - UNLESS OTHERWISE NOTED, THE GROUND BETWEEN PROPOSED ELEVATIONS SHALL BE GRADED AS A STRAIGHT LINE.
 - IF GRADING IS REQUIRED ON LANDS ADJACENT TO THE PROPERTY / DEVELOPMENT WHICH ARE NOT OWNED BY THE DEVELOPER, THEN THE DEVELOPER MUST OBTAIN WRITTEN PERMISSION FROM THE ADJACENT PROPERTY OWNER, OTHERWISE RETAINING WALLS MUST BE USED.
 - ALL RETAINING WALLS SHALL BE PLACED A MINIMUM 0.45M FROM PROPERTY LINES.
 - ANY WALL OF GREATER HEIGHT THAN 1.0M MUST BE DESIGNED BY A PROFESSIONAL ENGINEER.
 - TOP OF RETAINING WALL ELEVATIONS SHALL BE SET A MINIMUM OF 150MM ABOVE THE PROPOSED SIDE-YARD SWALES.
 - RETAINING WALLS 0.60M AND HIGHER REQUIRE CONSTRUCTION OF A FENCE OR GUARD RAIL AT THE TOP OF THE REAR OF THE WALL. SUCH FENCES OR GUARD RAILS SHALL BE DESIGNED AND CONSTRUCTED IN ACCORDANCE WITH THE REQUIREMENTS OF THE ONTARIO BUILDING CODE.
 - ALL FILL COMPACTED ON THE LOTS SHALL BE COMPACTED TO A MINIMUM 95% SPD (UNLESS OTHERWISE RECOMMENDED BY A GEOTECHNICAL ENGINEER). MATERIALS SHALL BE PLACED IN LIFTS NOT EXCEEDING 300MM DEPTH.
 - FOR DELINEATION OF TREE PROTECTION ZONES, BUFFERS, REMOVALS, AND PROTECTION SCHEMATICS REFER TO THE TREE PROTECTION PLAN (IF APPLICABLE).

- BACKYARD GRADING NOTES:**
- "REQUIRED BACKYARD" SHALL BE A MINIMUM OF 6.0 METRES UNLESS OTHERWISE DEFINED IN THE APPLICABLE ZONING BY-LAW.
 - THE MAXIMUM SLOPE IN THE BACKYARD ADJACENT TO THE BUILDING FOR A DISTANCE EQUAL TO THE REQUIRED BACKYARD SHALL BE 5% EXCEPT FOR SIDE OR REAR YARD SWALES AND RETAINING WALLS.
 - WHERE THE 5% RESTRICTION ON THE BACKYARD'S GRADES RESULTS IN ELEVATION DIFFERENCES BETWEEN ADJACENT PROPERTIES, RETAINING WALL SHALL BE CONSTRUCTED ALONG THE SIDES AND BACK OF THE LOT.
 - GENERALLY, SLOPES SHALL BE PLACED ON THE LOWER LOT, WHEREAS RETAINING WALLS SHALL BE PLACED ON THE HIGHER LANDS.
 - THE 5% RESTRICTION DOES NOT PRECLUDE RETAINING WALLS IN THE REQUIRED BACKYARDS PROVIDING THE TERRACES ARE MAINTAINED TO THE 5% GRADE AS SET OUT ABOVE. THE INTENTION OF THIS PROVISION IS TO PROVIDE FOR FLEXIBILITY OF HOUSE CONSTRUCTION.
 - BACK TO FRONT DRAINAGE SHALL ONLY BE PERMITTED WHERE THE COMBINED SIDE YARD SETBACK IS 2.0m OR MORE, PROVIDING A MINIMUM OF 2.0m BETWEEN FOUNDATION WALLS FOR DRAINAGE SWALES. A 1.2m SETBACK IS REQUIRED ON THE GARAGE SIDE OF THE LOT.

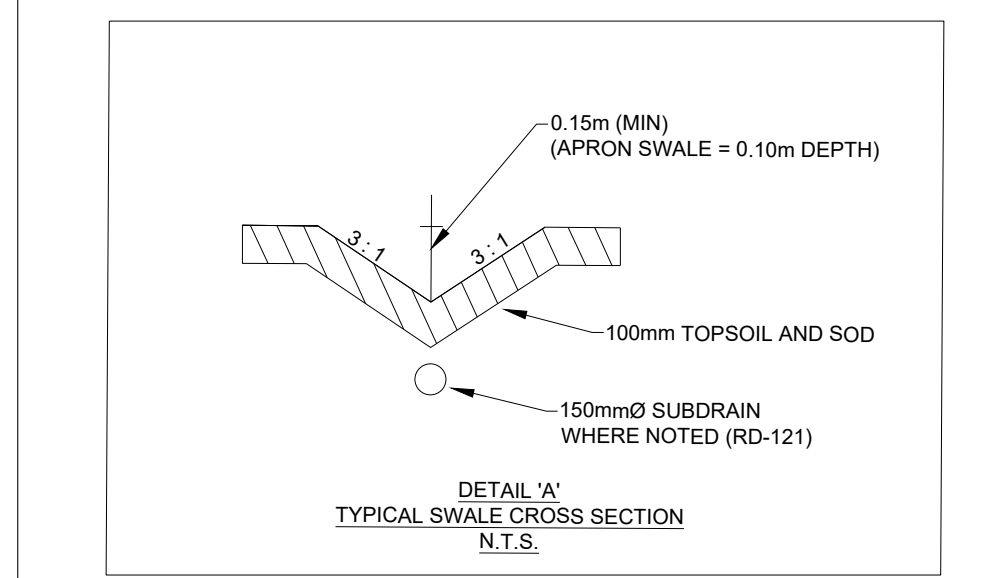
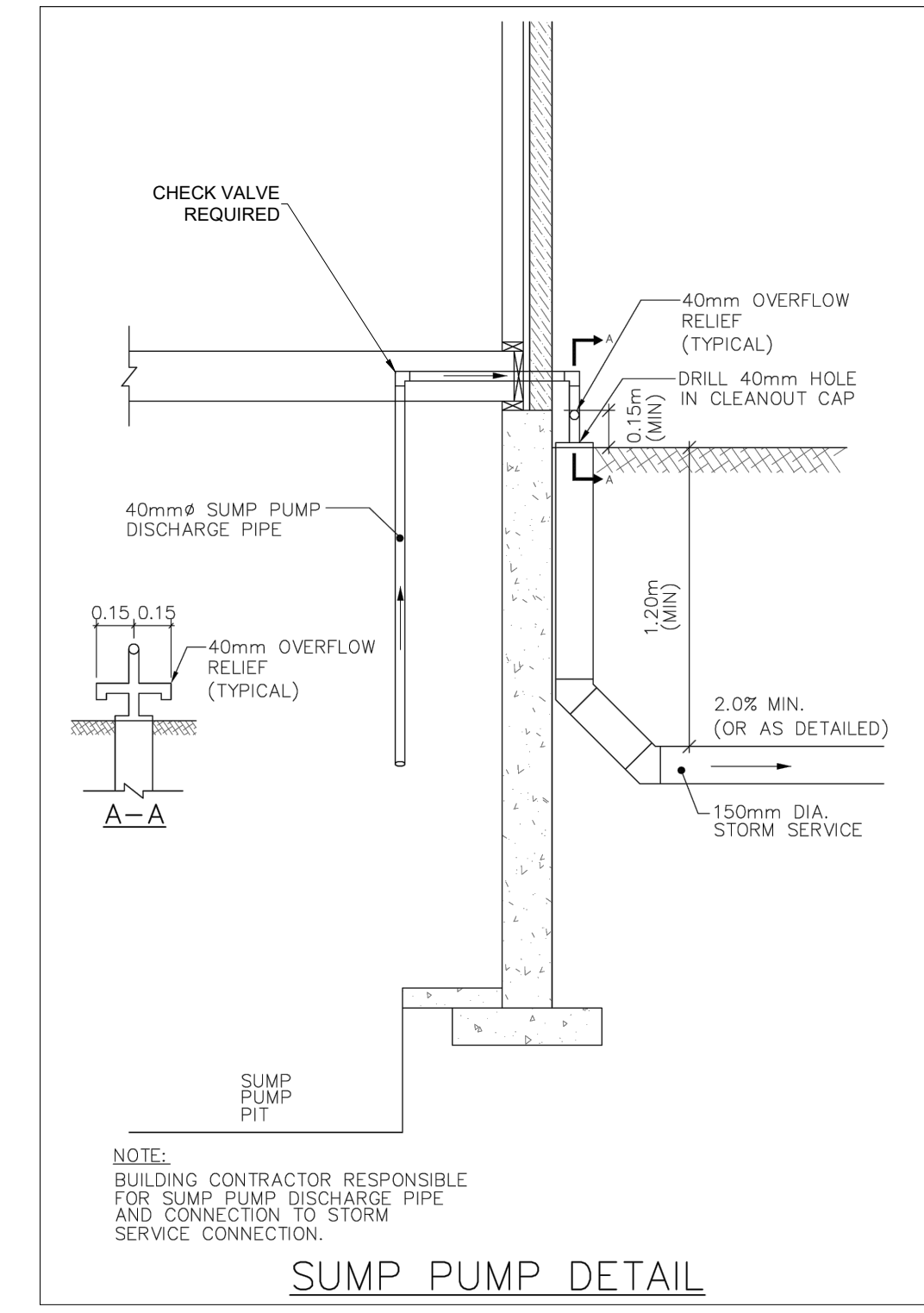

- NOTES:**
- LOCATIONS UNDERGROUND SERVICES ARE APPROXIMATE AND MUST BE FIELD VERIFIED PRIOR TO CONSTRUCTION.
 - ANY DISCREPANCIES BETWEEN SERVICE LOCATIONS AND THESE ENGINEERING DRAWINGS MUST BE BROUGHT TO THE ATTENTION OF THE PROJECT ENGINEER.

- GENERAL NOTES:**
- TENDERER SHALL SATISFY THEMSELVES AS TO THE NATURE OF THE GROUND AND BID ACCORDINGLY.
 - ALL ROCK LINE INDICATIONS SHOWN ON THE PLAN MUST BE VERIFIED BY THE CONTRACTOR.
 - CONTRACTOR SHALL VERIFY LOCATIONS AND INVERTS OF ALL EXISTING SANITARY AND STORM SEWERS AND WATERMAINS, PRIVATE DRAINS AND WATER SERVICES, GAS MAINS, CABLE TV, HYDRO AND TELEPHONE DUCTS ETC AT START OF CONSTRUCTION.

NO.	DATE	DESCRIPTION
	2023-05-09	REVISED PER CITY 1ST ROUND COMMENTS
1	2023-08-08	REVISED PER CITY 2ND ROUND COMMENTS
1	2023-05-08	REVISED PER CITY 1ST ROUND COMMENTS
0	2022-11-01	ISSUED FOR COORDINATION

REVISIONS	
	SEAL

LandSmith
ENGINEERING & CONSULTING LTD.

LANDSMITH ENGINEERING & CONSULTING LTD.
UNIT 207, 1065 UPPER JAMES ST.
HAMILTON, ON L9C 3A6
ANDREW@LANDSMITHCE.COM
289-309-3632

CLIENT:
QIANYE PROPERTY MANAGEMENT LIMITED

MUNICIPALITY:
CITY OF HAMILTON

PROJECT NAME:
253-259 LIMERIDGE ROAD WEST

TITLE:
PRELIMINARY GRADING PLAN

SCALE:	1:200	DATE:	2023-05-09
CHECKED BY:	AS	DESIGNED BY:	AS
DWG No:	22050QIA	SHEET No:	01

LIMERIDGE ROAD WEST

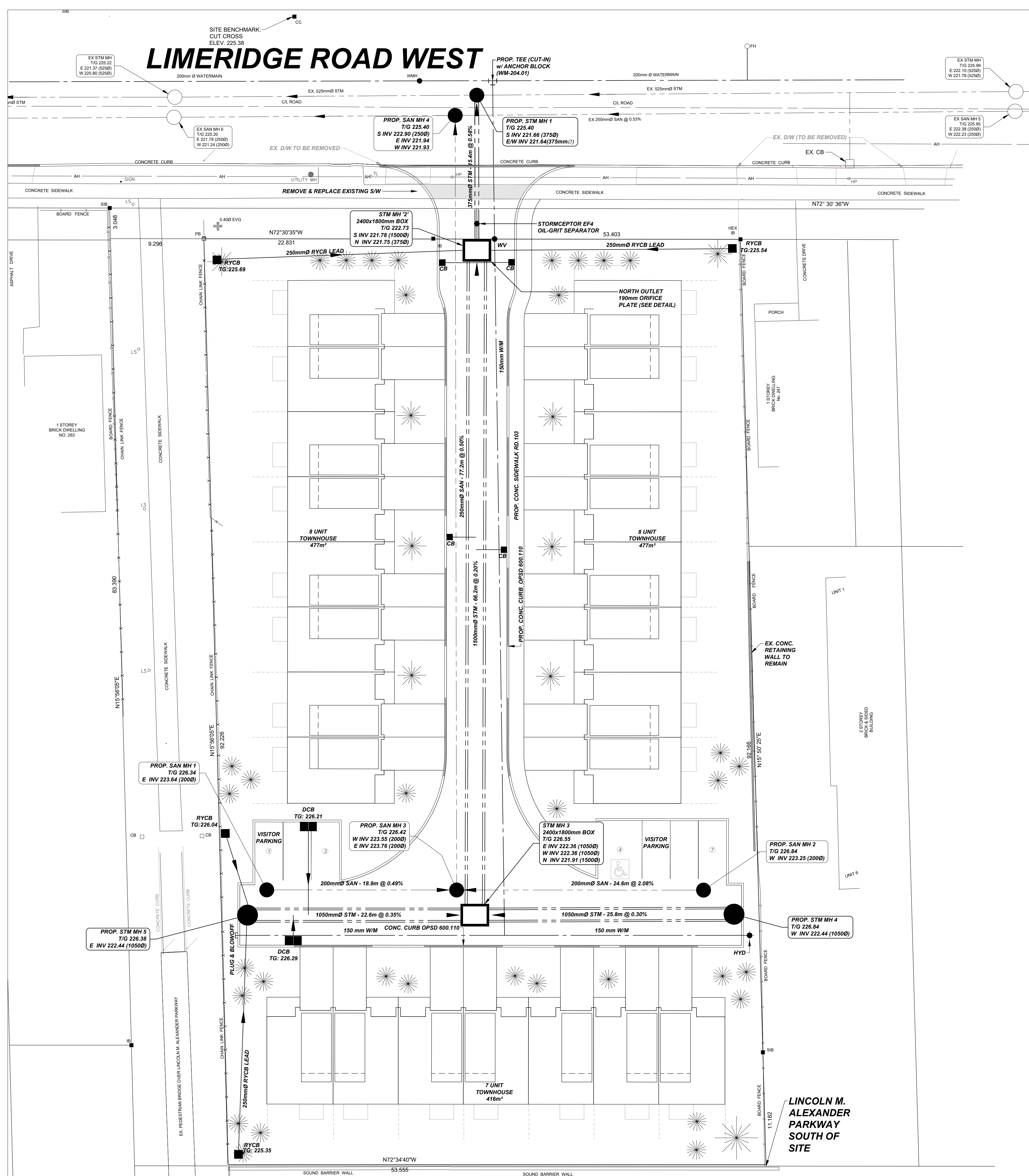

LEGEND

○ LS	EXISTING LIGHT STANDARD	—	EXISTING AERIAL HYDRO
● WV	PROPOSED WATER VALVE	—	EXISTING WATERMAIN
⊥ TEE	PROPOSED WATERMAIN TEE	—	PROPOSED WATER SERVICE
⊥ PLUG	PROPOSED PLUG	—	EXISTING SANITARY
● CS	PROPOSED CURB STOP	—	PROPOSED SANITARY
○ WV	EXISTING WATER VALVE	—	EXISTING STORM
○ GM	EXISTING GAS METER	—	PROPOSED STORM
○ HP	EXISTING HYDRO POLE	—	
○ CB	EXISTING CATCH BASIN	▨	PROPOSED SILT FENCE
○ SAN	EXISTING SANITARY MAINTENANCE HOLE	▨	ROADWAY RESTORATION
● SAN	PROPOSED SANITARY MAINTENANCE HOLE	▨	BOULEVARD RESTORATION
⊥ PLUG	EXISTING PLUG	○ C1	
⊥ PLUG	PROPOSED PLUG		
○ STM MH	EXISTING STORM MAINTENANCE HOLE		
● STM MH	PROPOSED STORM MAINTENANCE HOLE		
□ CB	EXISTING CATCH BASIN		
▨ CB	PROPOSED CATCH BASIN		
▨ DCB	EXISTING DOUBLE CATCH BASIN		
▨ DCB	PROPOSED DOUBLE CATCH BASIN		
● HYD	PROPOSED FIRE HYDRANT		
● FH	EXISTING FIRE HYDRANT		
●	OIL & GRIT SEPARATOR (SEE DETAIL)		

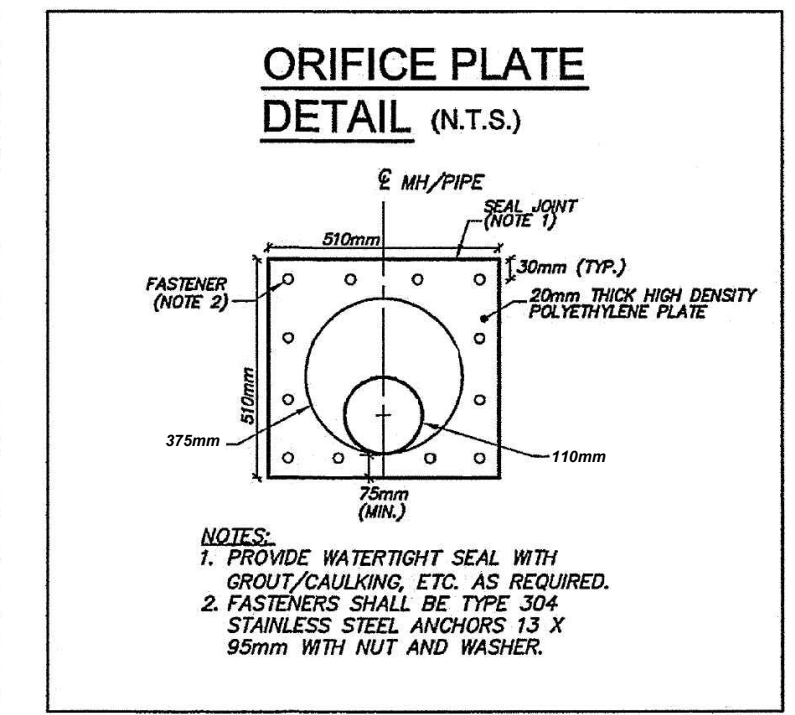
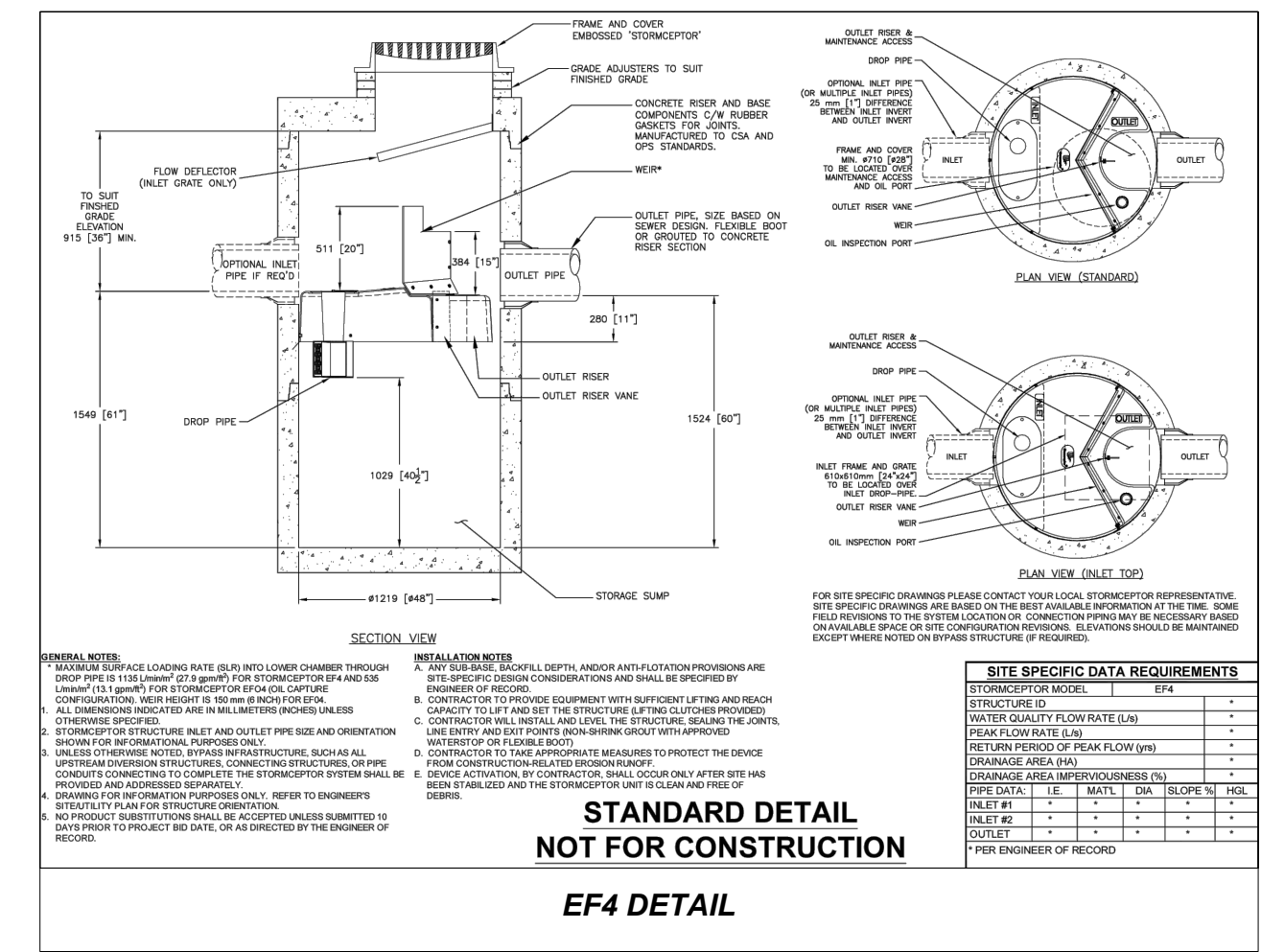

NOTES re: SEPARATION DISTANCES:

- Minimum horizontal separation between water services / mains and sewer drains and municipal sewer mains shall be 2.5m measured from the closest pipe edge to the closest pipe edge.
- Vertical separation where water service / main passes over a sewer drain or municipal sewer main must be a minimum 0.25m unless greater separation is required to provide proper bedding and structural support. Water services/mains passing under sewer drains or municipal sewer drains must have a separation of 0.50m between the invert of the sewer main/drain and the crown of the water service/main.

APPROVAL OF THIS DRAWING IS FOR MATERIAL ACCEPTABILITY AND COMPLIANCE WITH MUNICIPAL AND PROVINCIAL SPECIFICATIONS AND STANDARDS ONLY. APPROVAL AND INSPECTION BY THE CITY OF THE WORKS DOES NOT CERTIFY THE LINE AND GRADE OF THE WORKS AND IT IS THE OWNER'S RESPONSIBILITY TO HAVE THEIR ENGINEER CERTIFY THIS ACCORDINGLY.

NOTES:

- LOCATIONS UNDERGROUND SERVICES ARE APPROXIMATE AND MUST BE FIELD VERIFIED PRIOR TO CONSTRUCTION.
- ANY DISCREPANCIES BETWEEN SERVICE LOCATIONS AND THESE ENGINEERING DRAWINGS MUST BE BROUGHT TO THE ATTENTION OF THE PROJECT ENGINEER.



KEY PLAN N.T.S.

BENCHMARK NOTE:
ELEVATION = 225.38
MONUMENT: CUT-CROSS

BENCHMARK NOTE:
STATION: 007220081809

WEST FACE OF HOUSE NO. 355 LIMERIDGE ROAD LOCATED APPROXIMATELY 90m EAST OF THE LOT LINE BETWEEN WELLINGTON AND WENTWORTH STREETS. PLAGUE IS SET 1m NORTH IN SECOND FROM THE TOP CONCRETE BLOCK OF THE SOUTHWEST CORNER OF THE HOUSE.

NO. 967 ELEVATION 207.201

- GENERAL NOTES:**
- TENDERER SHALL SATISFY THEMSELVES AS TO THE NATURE OF THE GROUND AND BID ACCORDINGLY.
 - ALL ROCK LINE INDICATIONS SHOWN ON THE PLAN MUST BE VERIFIED BY THE CONTRACTOR.
 - CONTRACTOR SHALL VERIFY LOCATIONS AND INVERTS OF ALL EXISTING SANITARY AND STORM SEWERS AND WATERMANS, PRIVATE DRAINS AND WATER SERVICES, GAS MAINS, CABLE TV, HYDRO AND TELEPHONE DUCTS ETC AT START OF CONSTRUCTION.

NO.	DATE	DESCRIPTION
1	2023-05-09	REVISED PER CITY 1ST ROUND COMMENTS
2	2023-08-08	REVISED PER CITY 2ND ROUND COMMENTS
1	2023-05-08	REVISED PER CITY 1ST ROUND COMMENTS
0	2022-11-01	ISSUED FOR COORDINATION

REVISIONS	

LandSmith ENGINEERING & CONSULTING LTD.
LANDSMITH ENGINEERING & CONSULTING LTD.
UNIT 207, 1065 UPPER JAMES ST.
HAMILTON, ON L9C 3A6
ANDREW@LANDSMITH.CA
289-309-3632

CLIENT: QIANYE PROPERTY MANAGEMENT LIMITED

MUNICIPALITY: CITY OF HAMILTON

PROJECT NAME: 253-259 LIMERIDGE ROAD WEST

TITLE: PRELIMINARY SERVICING PLAN

SCALE: 1:200	DATE: 2023-05-09
CHECKED BY: AS	DESIGNED BY: AS
DWG No: 220500IA	SHEET No: 02

LIMERIDGE ROAD WEST

SITE BENCHMARK:
CUT CROSS
ELEV. 225.38

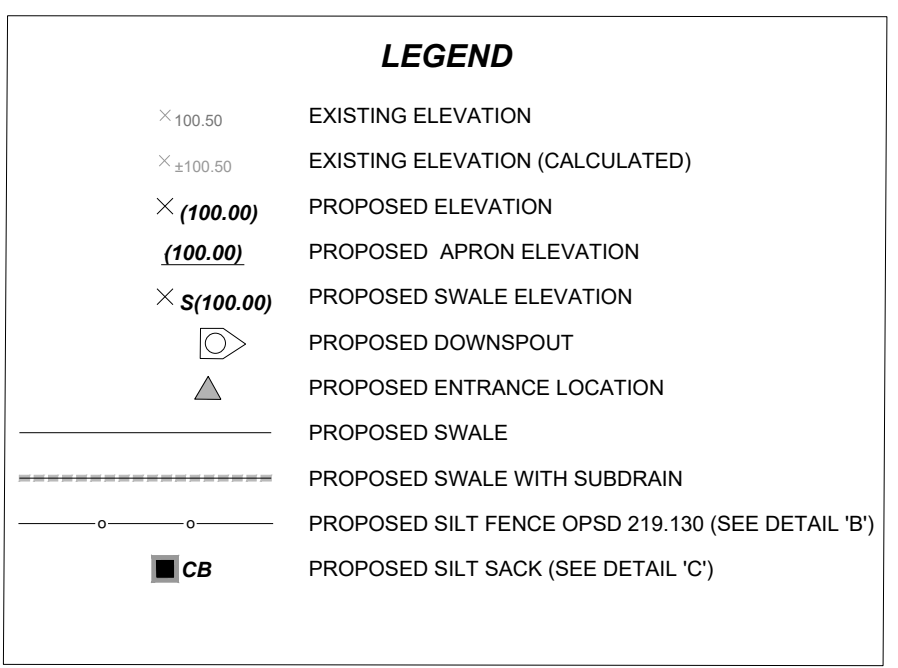
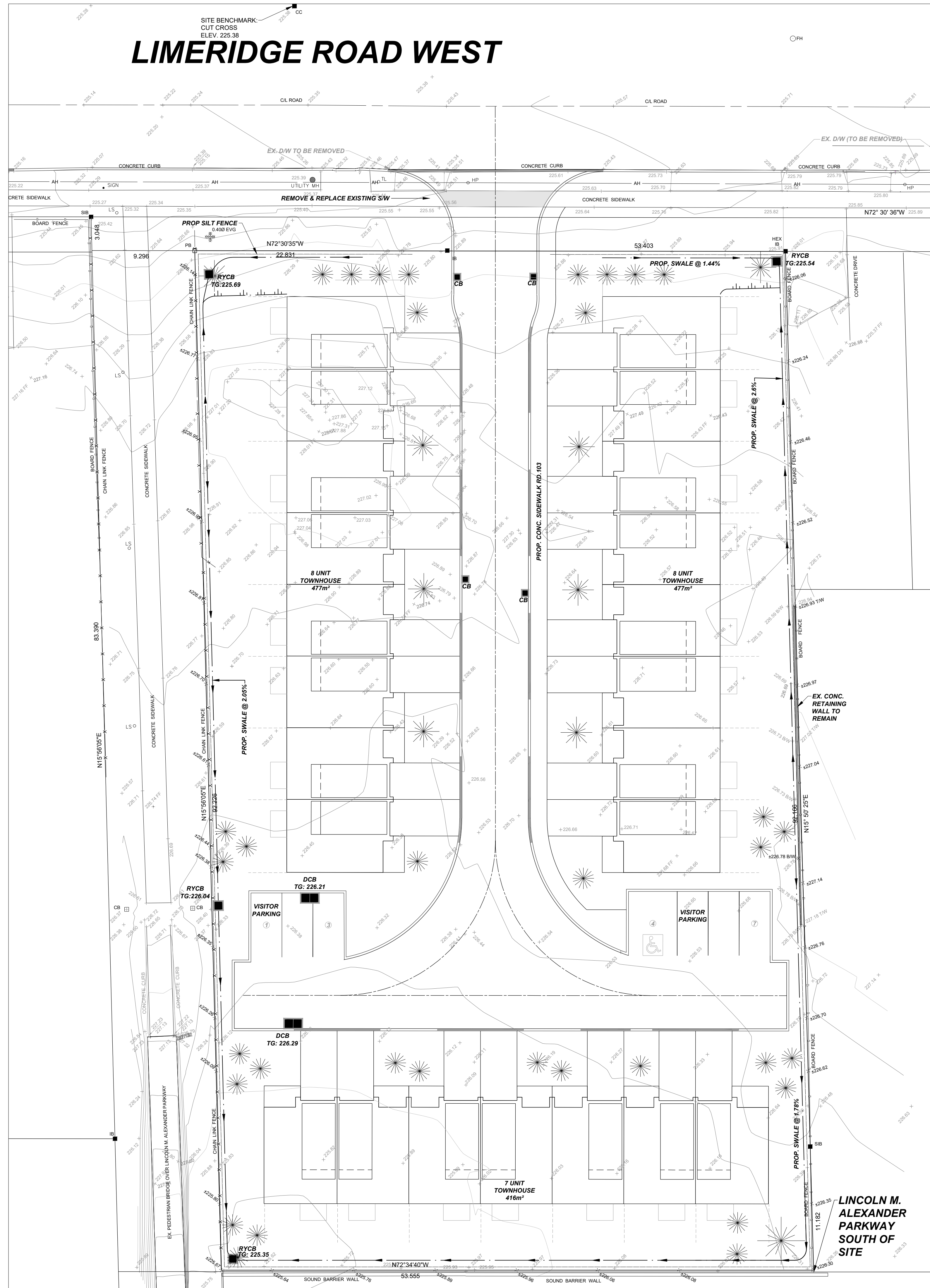

- #### SILTATION AND EROSION CONTROL NOTES:
- SILTATION CONTROL BARRIERS SHALL BE PLACED AS DETAILED ON THE PLAN ACCORDING TO OPSD 219.130 (SEE DETAIL ON THIS SHEET).
 - ALL SILTATION CONTROL MEASURES SHALL BE CLEANED AND MAINTAINED AFTER EACH RAINFALL EVENT TO THE SATISFACTION OF THE CITY OF HAMILTON.
 - CATCH BASIN SEDIMENT CONTROL DEVICES SHALL BE SILTSACK BY ACF ENVIRONMENTAL OR APPROVED EQUIVALENT, TO BE PLACED AS PER THE MANUFACTURER'S RECOMMENDATIONS (IF APPLICABLE).
 - ADDITIONAL SILTATION CONTROL MEASURES MAY BE REQUIRED AS PER FIELD CONDITIONS AS DETERMINED BY THE CITY.
 - SILTATION CONTROL BARRIERS SHALL BE PACED AS DETAILED
 - ALL SILTATION CONTROL MEASURES SHALL BE CLEANED AND MAINTAINED AFTER EVERY RAINFALL AS DIRECTED TO THE SATISFACTION OF THE CITY OF HAMILTON.
 - SILTATION AND EROSION CONTROL DEVICES SHALL BE INSTALLED PRIOR TO WORKS COMMENCING ON SITE AND SHALL BE MAINTAINED FOR THE DURATION OF CONSTRUCTION UNTIL GROUND COVER IS ESTABLISHED AND THE SITE IS FULLY DEVELOPED.
 - EROSION & SEDIMENT CONTROLS MUST BE INSPECTED ON A REGULAR BASIS AFTER EVERY RAINFALL EVENT, AND MUST BE MAINTAINED AND REPAIRED IN A TIMELY MANNER TO PREVENT SEDIMENT FROM LEAVING THE SITE.
 - EXISTING AND PROPOSED CATCHBASINS ARE TO BE PROTECTED WITH A SILTSACK FOR THE DURATION OF CONSTRUCTION.
 - IT IS REQUIRED TO STABILIZE ALL AREAS THAT WILL REMAIN DISTRUSTED FOR MORE THAN 30 DAYS.
 - SILT FENCE AND CATCH BASIN PROTECTION ARE NOT TO BE REMOVED UNTIL COMPLETION OF CONSTRUCTION.
 - THE SILTATION AND EROSION CONTROL MEASURES ILLUSTRATED ON THIS PLAN ARE CONSIDERED MINIMUM REQUIREMENT. CONDITIONS MAY REQUIRE ADDITIONAL MEASURES WHICH WILL BE IDENTIFIED BY THE ENGINEER DURING CONSTRUCTION.
 - ALL EROSION AND SEDIMENT CONTROL DEVICES SHOULD BE AS PER THE "GREATER GOLDEN HORSESHOE AREA CONSERVATION AUTHORITIES", "EROSION AND SEDIMENT CONTROL GUIDELINE FOR URBAN CONSTRUCTION".
 - THE OWNER IS RESPONSIBLE FOR THE REMOVAL OF ALL MUD AND DEBRIS THAT ARE TRACKED ONTO THE ROADWAYS FROM VEHICLES ENTER AND LEAVING THE CONSTRUCTION SITE. THE OWNER SHALL, UPON VERBAL AND/OR REQUEST BY THE CITY, IMMEDIATELY PROCEED WITH THE CLEANUP OPERATION AT THEIR EXPENSE. SHOULD THE OWNER FAIL TO MAINTAIN THE ROAD AS DIRECTED, THE CITY WILL HAVE THE CLEANING CARRIED OUT, AND DRAW ON THE SECURITY FOR COST AND/OR LAY CHARGES.

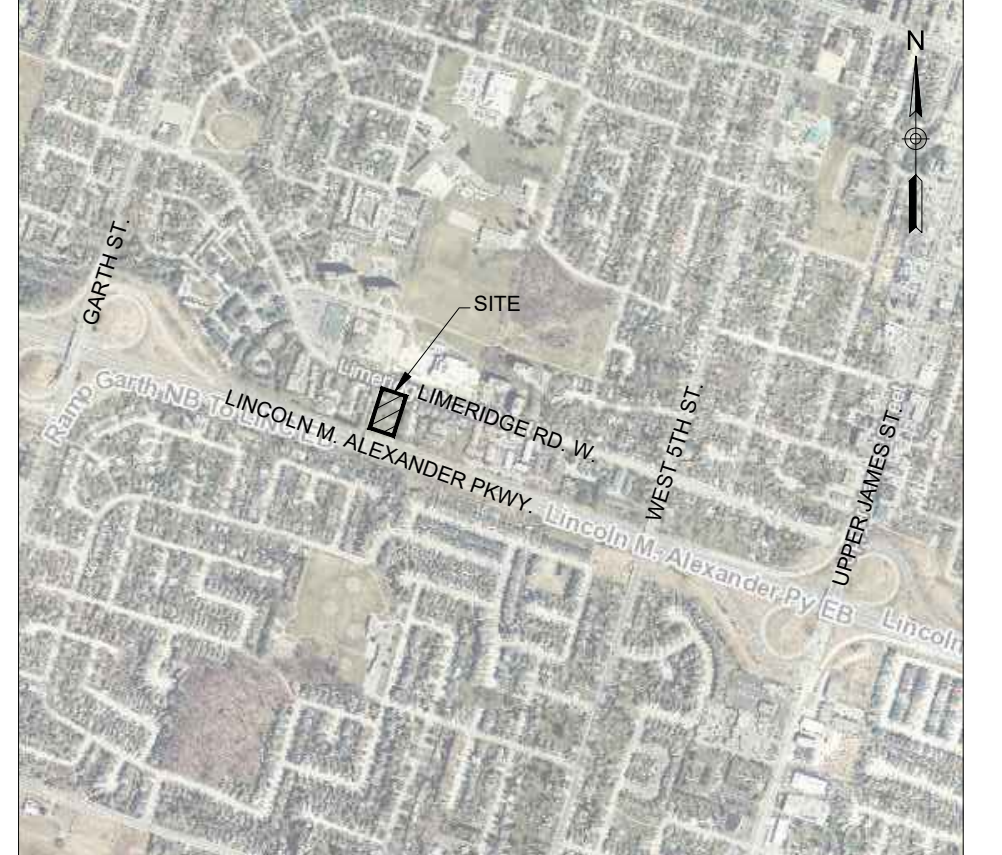

KEY PLAN N.T.S.

BENCHMARK NOTE:
ELEVATION = 225.38
MONUMENT: CUT-CROSS NORTH OF SITE

BENCHMARK NOTE:
STATION: 00722091809
WEST FACE OF HOUSE NO. 355 LIMERIDGE ROAD LOCATED APPROXIMATELY 90m EAST OF THE LOT LINE BETWEEN WELLINGTON AND WENTWORTH STREETS. PLAGUE IS SET 1m NORTH IN SECOND FROM THE TOP CONCRETE BLOCK OF THE SOUTHWEST CORNER OF THE HOUSE.
NO. 967 ELEVATION 207.201

- #### GENERAL NOTES:
- TENDERER SHALL SATISFY THEMSELVES AS TO THE NATURE OF THE GROUND AND BID ACCORDINGLY.
 - ALL ROCK LINE INDICATIONS SHOWN ON THE PLAN MUST BE VERIFIED BY THE CONTRACTOR.
 - CONTRACTOR SHALL VERIFY LOCATIONS AND INVERTS OF ALL EXISTING SANITARY AND STORM SEWERS AND WATERMANS, PRIVATE DRAINS AND WATER SERVICES, GAS MAINS, CABLE TV, HYDRO AND TELEPHONE DUCTS ETC AT START OF CONSTRUCTION.

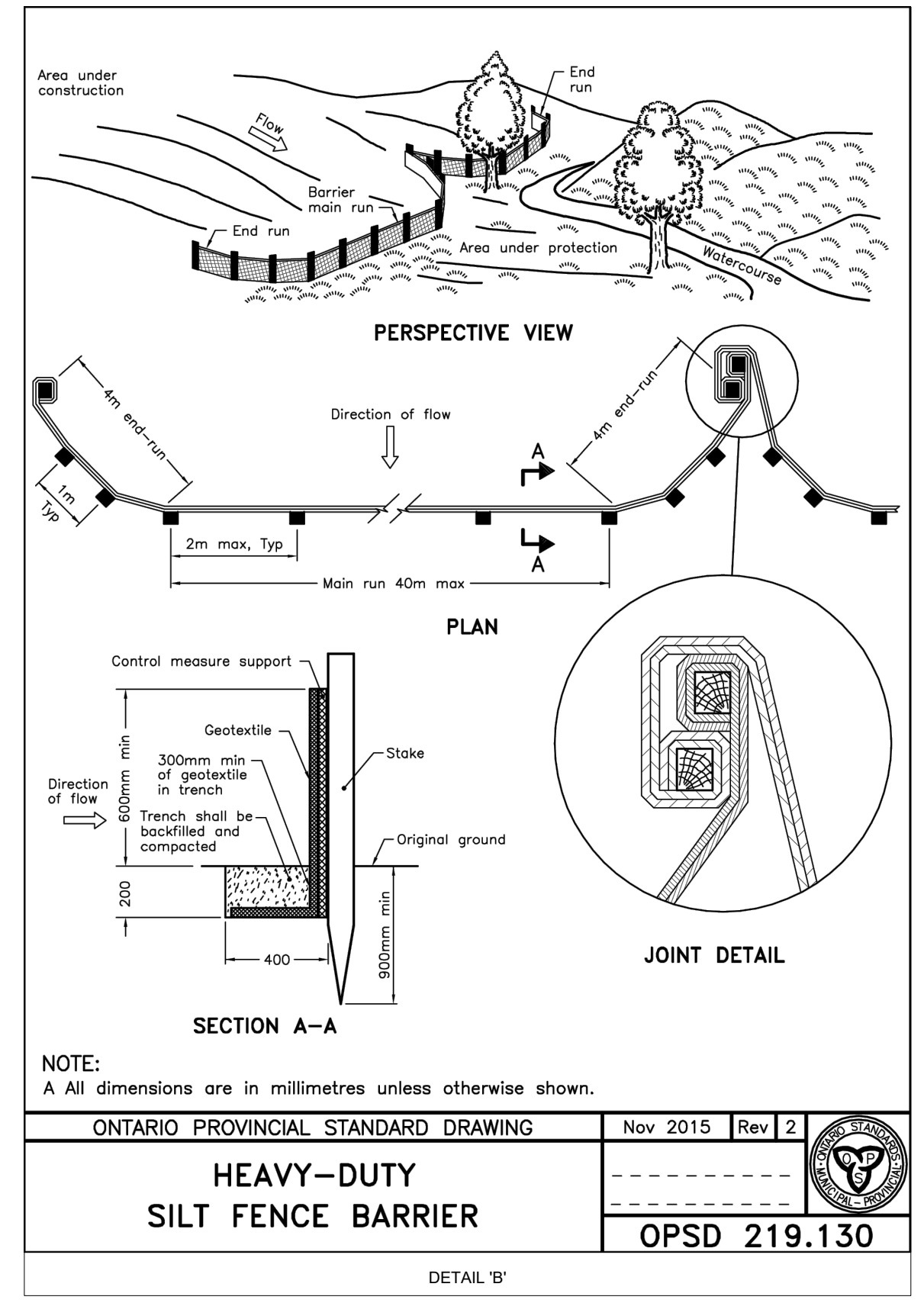
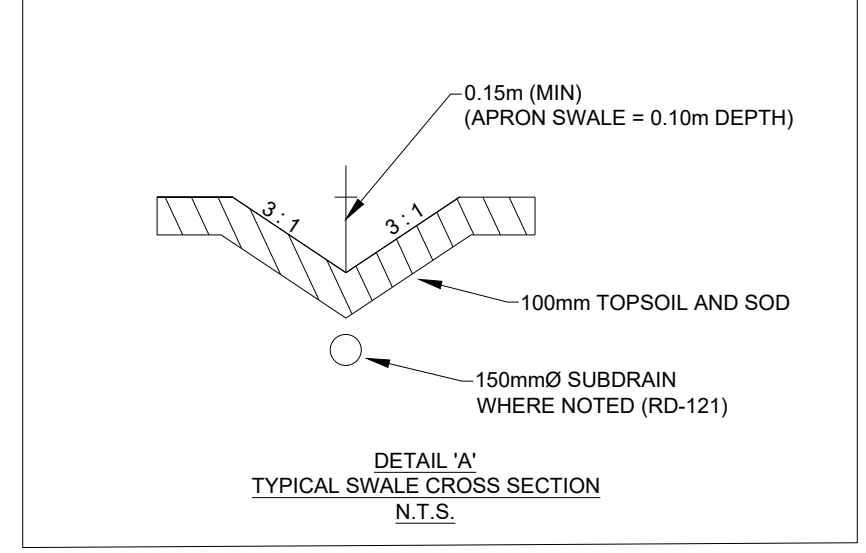

NOTE:
A All dimensions are in millimetres unless otherwise shown.

ONTARIO PROVINCIAL STANDARD DRAWING Nov 2015 Rev 2

HEAVY-DUTY SILT FENCE BARRIER

OPSD 219.130

DETAIL 'B'

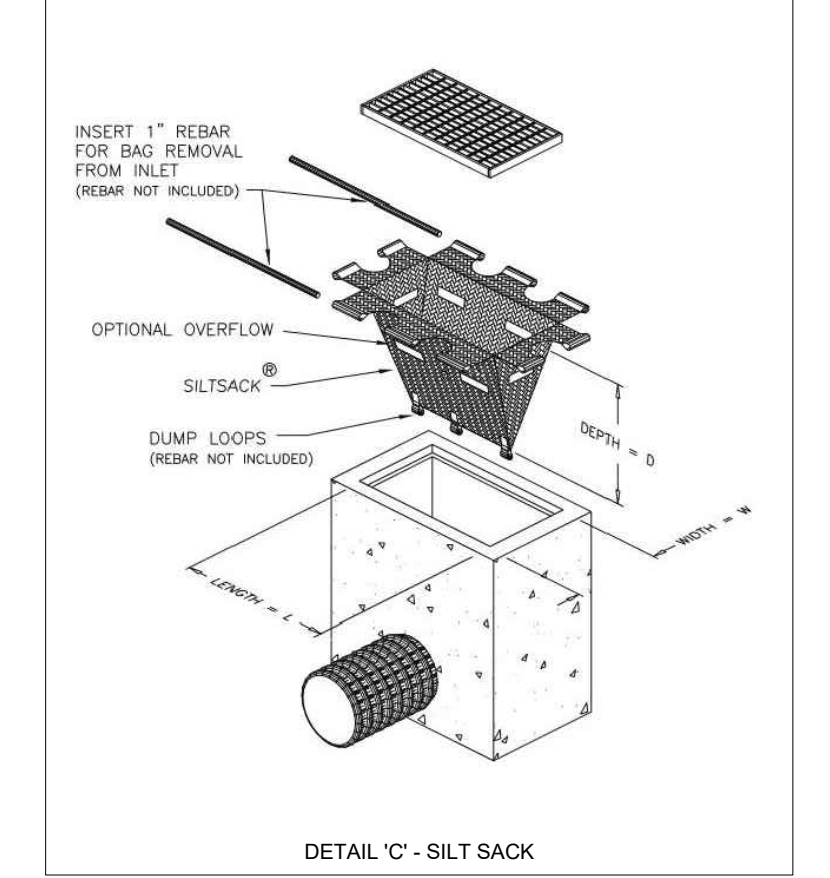

- #### NOTES:
- LOCATIONS UNDERGROUND SERVICES ARE APPROXIMATE AND MUST BE FIELD VERIFIED PRIOR TO CONSTRUCTION.
 - ANY DISCREPANCIES BETWEEN SERVICE LOCATIONS AND THESE ENGINEERING DRAWINGS MUST BE BROUGHT TO THE ATTENTION OF THE PROJECT ENGINEER.

NO.	DATE:	DESCRIPTION:
0	2023-05-09	REVISED PER CITY 1ST ROUND COMMENTS
0	2022-12-16	FIRST SUBMISSION

LANDSMITH ENGINEERING & CONSULTING LTD.
UNIT 207, 1065 UPPER JAMES ST.
HAMILTON, ON L9C 3A6
ANDREW@LANDSMITHCE.COM
289-309-3632

CLIENT: QIANYE PROPERTY MANAGEMENT LIMITED

MUNICIPALITY: CITY OF HAMILTON

PROJECT NAME: 253-259 LIMERIDGE ROAD WEST

TITLE: SILTATION & EROSION CONTROL PLAN

SCALE: 1:200 DATE: 2023-05-09

CHECKED BY: AS DESIGNED BY: AS

DWG No: 22050QIA SHEET No: 06

APPENDIX 'B' – Water/Wastewater Servicing Analysis

Fire Protection Plan

Required Fire-Flow Calculations

Domestic Water Usage Calculations

Sanitary Drainage Area Plan

Sanitary Sewer Design Sheet

Overall Sanitary Drainage Area Plan

Overall Sanitary Sewer Design Sheet

LEGEND



UNIT SQUARE METER AREA

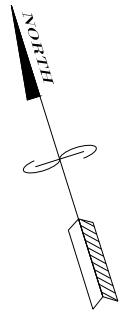

SITE BENCHMARK:
CUT CROSS
ELEV. 225.38

PROP. TEE (CUT-IN)
w/ ANCHOR BLOCK
(WM-204.01)

200mm Ø WATERMAIN

WMH

200mm Ø WATERMAIN

C/L ROAD

C/L ROAD

EX. D/W TO BE REMOVED

CONCRETE CURB

CONCRETE CURB

100.00m+

CONCRETE SIDEWALK

SIB L5

CE L5

3.048

9.296

N72°30'35"W

22.831

0.400 EVG

PB

CHAIN LINK FENCE

CONCRETE SIDEWALK

L5

83.390

N15°56'05"E

BOARD FENCE

CHAIN LINK FENCE

CONCRETE SIDEWALK

L5

83.390

N15°56'05"E

CHAIN LINK FENCE

CONCRETE SIDEWALK

L5

83.390

N15°56'05"E

CHAIN LINK FENCE

CONCRETE SIDEWALK

L5

83.390

N15°56'05"E

CHAIN LINK FENCE

CONCRETE SIDEWALK

L5

83.390

N15°56'05"E

CHAIN LINK FENCE

CONCRETE SIDEWALK

L5

83.390

N15°56'05"E

CHAIN LINK FENCE

CONCRETE SIDEWALK

L5

83.390

N15°56'05"E

CHAIN LINK FENCE

CONCRETE SIDEWALK

L5

83.390

N15°56'05"E

CHAIN LINK FENCE

CONCRETE SIDEWALK

L5

83.390

N15°56'05"E

CHAIN LINK FENCE

CONCRETE SIDEWALK

L5

83.390

N15°56'05"E

CHAIN LINK FENCE

CONCRETE SIDEWALK

L5

83.390

N15°56'05"E

CHAIN LINK FENCE

CONCRETE SIDEWALK

L5

83.390

N15°56'05"E

CHAIN LINK FENCE

CONCRETE SIDEWALK

L5

83.390

N15°56'05"E

CHAIN LINK FENCE

CONCRETE SIDEWALK

L5

83.390

N15°56'05"E

CHAIN LINK FENCE

CONCRETE SIDEWALK

L5

83.390

N72°30'35"W

53.403

HEX IB

CONCRETE DRIVE

7.33m

PORCH

1 STOREY BRICK DWELLING No. 247

8 UNIT TOWNHOUSE 477m²

8 UNIT TOWNHOUSE 477m²

EX. CONC. RETAINING WALL TO REMAIN

UNIT 1

2 STOREY BRICK DWELLING

UNIT 6

LINCOLN M. ALEXANDER PARKWAY SOUTH OF SITE



1:300



PROJECT: 253-259 LIMERIDGE RD. W.

FIRE PROTECTION PLAN

SHEET NO. 8

FIRE FLOW DEMAND REQUIREMENTS

Project: 253 - 259 Limeridge Road West
 Method: OFM-TG-03-1999
 FIRE PROTECTION WATER SUPPLY GUIDELINE FOR PART 3 IN THE ONTARIO BUILDING CODE
<http://www.mcscs.ius.gov.on.ca/english/FireMarshal/Legislation/TechnicalGuidelinesandReports/TG-1999-03.html>

Formula:

$$Q = K \times V \times S_{Tot}$$

Where: Q = minimum supply of water in litres
 K = water supply coefficient (Table 1)
 V = total building volume in cubic meters
 S_{Tot} = total of spacial coefficient tables

Volume (V)

1st + 2nd + 3rd + Roof Volume

Ground Floor Area: 477 (sq.m)
 Height: 10.76 (m)
 Volume 1 (Building): 5132.52 (cu.m)

Total Volume (V) = 5132.5 (cu.m)

Water Supply Coefficient (K)

K: 18

OBC Part: C (Residential)

Construction Type: *Building is of combustible construction with fire separations and fire-resistance ratings provided in accordance with Subsection 3.2.2. of the OBC, including loadbearing walls, columns and arches. Noncombustible construction may be used in lieu of fire-resistance rating where permitted in Subsection 3.2.2. of the OBC.*

Spacial Coefficients (S)

	Distance	
S ₁	0	100 (North)
S ₂	0.567	7.33 (East)
S ₃	0	19.31 (South)
S ₄	0	17.88 (West)

S_{Tot} = 1.0 + S₁ + S₂ + S₃ + S₄ = 1.567

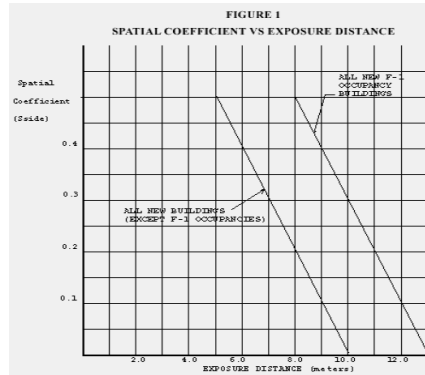

Q = 144,767

Required Flow Rate (OBC) = 5,400 L / Min
= 90 L / Sec

City of Hamilton Target Flow for residential units (greater than 3 units) and commercial land use = 150 L/s <---Governs

Building Code, Part 3 Buildings	Required Minimum Water Supply Flow Rate (L/min.)
One-storey building with building area not exceeding 600m ² (excluding F-1 occupancies)	1800
All other buildings	2700 (If Q ≤ 108,000L) ⁽¹⁾ 3600 (If Q > 108,000L and ≤ 135,000L) ⁽¹⁾ 4500 (If Q > 135,000L and ≤ 162,000L) ⁽¹⁾ 5400 (If Q > 162,000L and ≤ 190,000L) ⁽¹⁾ 6300 (If Q > 190,000L and ≤ 270,000L) ⁽¹⁾ 9000 (If Q > 270,000L) ⁽¹⁾

DOMESTIC WATER USEAGE REQUIREMENTS

Project: 253 & 259 Limeridge Road West
 Method: Fixture Unit Method, Per OBC Table 7.6.3.2.A

Fixtures: The number of fixtures was calculated based on the Concept Floor plans provided by KNYMH, dated Nov. 22, 2022 (See Appendix 'A').

<u>Amount</u>	<u>Fixture Type</u>	<u>Fixture Units Per</u>	<u>Total</u>
23	Watercloset	3	69
23	Private Bathroom Group	3.6	82.8
23	Dishwasher	1.4	32.2
23	Kitchen Sink	1.4	32.2
23	Clothes Washer	1.4	32.2
23	Hose Bib	2.5	57.5
	Total:		248.4

248

1 - Reference Table 7.6.3.2.A, Ontario Building Code

Hydraulic Load: Fixture units are then transferred to Hydraulic Load based on Ontario Building Code Table 7.4.10.5.

Column 1	Column 2	Column 3	Column 4
<i>Fixture Units in service</i>	<i>Max Drainage Rate (Gal/m)</i>		
	Col. 1	Col. 1 × 10	Col. 1 × 100
100	53	174	900
90	51	164	835
80	49	153	750
70	47	140	680
60	44	128	600
50	41	115	520
40	38	102	435
30	33	88	350
20	27	72	262
10	21	53	174

Maximum hydraulic load is estimated to be 80 (79.4) Imperial Gallons / Minute

248.4 Fixture Units = 80 lpgm = **6.06** L/s

The estimated maximum hydraulic load for the proposed development (23 Units) is 6.06 Lps

LIMERIDGE ROAD WEST



LEGEND

- EXISTING SANITARY
- - - PROPOSED SANITARY
- SAN EXISTING SANITARY MAINTENANCE HOLE
- SAN PROPOSED SANITARY MAINTENANCE HOLE
- PLUG EXISTING PLUG
- PLUG PROPOSED PLUG
- HYD PROPOSED FIRE HYDRANT
- FH EXISTING FIRE HYDRANT

0.077 AREA (HECTARES)
1 141 POPULATION DENSITY
DRAINAGE AREA NO.

KEY PLAN N.T.S.

BENCHMARK NOTE:
ELEVATION = 225.38
MONUMENT: CUT-CROSS

BENCHMARK NOTE:
STATION: 007220081809

WEST FACE OF HOUSE NO. 355 LIMERIDGE ROAD LOCATED APPROXIMATELY 90m EAST OF THE LOT LINE BETWEEN WELLINGTON AND WENTWORTH STREETS. PLAGUE IS SET 1m NORTH IN SECOND FROM THE TOP CONCRETE BLOCK OF THE SOUTHWEST CORNER OF THE HOUSE.

NO. 967 ELEVATION 207.201

- GENERAL NOTES:**
- TENDERER SHALL SATISFY THEMSELVES AS TO THE NATURE OF THE GROUND AND BID ACCORDINGLY.
 - ALL ROCK LINE INDICATIONS SHOWN ON THE PLAN MUST BE VERIFIED BY THE CONTRACTOR.
 - CONTRACTOR SHALL VERIFY LOCATIONS AND INVERTS OF ALL EXISTING SANITARY AND STORM SEWERS AND WATERMANS, PRIVATE DRAINS AND WATER SERVICES, GAS MAINS, CABLE TV, HYDRO AND TELEPHONE DUCTS ETC AT START OF CONSTRUCTION.

NO.	DATE:	DESCRIPTION:
0	2022-12-16	FIRST SUBMISSION
	2023-05-09	REVISED PER CITY 1ST ROUND COMMENTS

REVISIONS

NO.	DATE:	DESCRIPTION:

LandSmith ENGINEERING & CONSULTING LTD.
LANDSMITH ENGINEERING & CONSULTING LTD.
UNIT 207, 1055 UPPER JAMES ST.
HAMILTON, ON L9C 3A6
ANDREW@LANDSMITHEC.COM
289-309-3632

CLIENT:
QIANYE PROPERTY MANAGEMENT LIMITED

MUNICIPALITY:
CITY OF HAMILTON

PROJECT NAME:
253-259 LIMERIDGE ROAD WEST

TITLE:
SANITARY DRAINAGE AREA PLAN

SCALE:	1:200	DATE:	2023-05-09
CHECKED BY:	AS	DESIGNED BY:	AS
DWG No:	220500IA	SHEET No:	03

- NOTES re: SEPARATION DISTANCES:**
- Minimum horizontal separation between water services / mains and sewer drains and municipal sewer mains shall be a minimum 0.25m unless greater separation is required to provide proper bedding and structural support. Water services/mains passing under sewer drains or municipal sewer drains must have a separation of 0.50m between the invert of the sewer main/drain and the crown of the water service/main.
 - Vertical separation where water service / main passes over a sewer drain or municipal sewer main must be a minimum 0.25m unless greater separation is required to provide proper bedding and structural support. Water services/mains passing under sewer drains or municipal sewer drains must have a separation of 0.50m between the invert of the sewer main/drain and the crown of the water service/main.

APPROVAL OF THIS DRAWING IS FOR MATERIAL ACCEPTABILITY AND COMPLIANCE WITH MUNICIPAL AND PROVINCIAL SPECIFICATIONS AND STANDARDS ONLY. APPROVAL AND INSPECTION BY THE CITY OF THE WORKS DOES NOT CERTIFY THE LINE AND GRADE OF THE WORKS AND IT IS THE OWNER'S RESPONSIBILITY TO HAVE THEIR ENGINEER CERTIFY THIS ACCORDINGLY.

- NOTES:**
- LOCATIONS UNDERGROUND SERVICES ARE APPROXIMATE AND MUST BE FIELD VERIFIED PRIOR TO CONSTRUCTION.
 - ANY DISCREPANCIES BETWEEN SERVICE LOCATIONS AND THESE ENGINEERING DRAWINGS MUST BE BROUGHT TO THE ATTENTION OF THE PROJECT ENGINEER.

SANITARY SEWER DESIGN SHEET



DATE: DEC. 16, 2022 FILE No.: 22050QIA
 DESIGNED: BC PROJECT: 253-259 LIMERIDGE RD. W.
 CHECKED: AS

q = average per capita daily flow 360
 p = unit of population density 3.00

P = population
 M = peaking factor (Babbitt)
 P = p x # units / 1000
 M = 5 / (P/1000) * 0.20
 Q = (P x q x M) / 86.4

Q(p) = peak population flow (L/s)
 Q(i) = peak extraneous flow (L/s)

SHEET No.:
1 OF 1

158 Q(d) = peak design flow (L/s)
 Actual

Infiltration Allowance: 0.400 L / s / ha

Area #	LOCATION			POP DENSITY (pp/ha)	RES. AREA (ha)	POP	CUMULATIVE		PEAKING FACTOR (M)	POPULATION FLOW, Q(p) (L/s)	PEAK EXTRANEIOUS FLOW, Q(i) (L/s)	PEAK DESIGN FLOW, Q(d) (L/s)	PROPOSED SANITARY SEWER							
	STREET	FROM MH	TO MH				POP	TOTAL AREA (ha)					LENGTH (m)	PIPE SIZE DIAMETER (mm)	GRADE (%)	MANNING'S n	CAPACITY (L/s)	FULL FLOW VELOCITY (m/s)	ACTUAL VELOCITY (m/s)	PERCENT FULL
1	STREET B	1	3	141	0.08	10.86	11	0.08	5.00	0.23	0.03	0.26	18.4	200	0.50%	0.013	23.2	0.74	0.25	1.1%
2	STREET B	2	3	141	0.10	13.96	14	0.10	5.00	0.29	0.04	0.33	25.5	200	2.00%	0.013	46.4	1.48	0.45	0.7%
3	STREET A	3	4	141	0.32	44.84	70	0.49	5.00	1.45	0.20	1.65	77.2	250	0.50%	0.013	42.0	0.86	0.41	3.9%



LEGEND

0.03 DRAINAGE AREA (HECTARES)
 1 LOW 10U 35P # OF UNITS
 1 LOW 11P # OF PERSONS

DRAINAGE AREA NUMBER

DRAINAGE AREA BOUNDARY
 DRAINAGE SUB-AREA BOUNDARY

DENSITY TYPES

LOW DENSITY = 3.405 PERSONS PER UNIT*
 MEDIUM DENSITY = 2.437 PERSONS PER UNIT*
 HIGH DENSITY = 1.663 PERSONS PER UNIT*
 COMMERCIAL/INSTITUTIONAL = 125 PPHA

*VALUES BASED ON CITY OF HAMILTON'S DEVELOPMENT CHARGES BACKGROUND STUDY, 2019



KEY PLAN N.T.S.

BENCHMARK NOTE:
 ELEVATION = 248.131 (CGVD-1928)
 MONUMENT: 0011975U132

PUMPING STATION, WILSON STREET AT SEMINOLE ROAD, TABLE IN TOP OF CONCRETE WELL 27.4m SOUTHEAST OF CENTRELINE OF WILSON STREET, 18.0m NORTHEAST OF CENTRELINE OF SEMINOLE ROAD, 15.2m SOUTHEAST OF HYDRO POLE, 8.2m SOUTHWEST OF CORNER OF PUMP HOUSE.

SITE BENCHMARK:
 ELEVATION = 251.07m
 CUT-STAR IN MUNICIPAL SIDEWALK ON EAST SIDE OF FIDDLER'S GREEN ROAD AT SITE FRONTAGE AS INDICATED ON PLAN.

- GENERAL NOTES:**
- TENDERER SHALL SATISFY THEMSELVES AS TO THE NATURE OF THE GROUND AND BID ACCORDINGLY.
 - ALL ROCK LINE INDICATIONS SHOWN ON THE PLAN MUST BE VERIFIED BY THE CONTRACTOR.
 - CONTRACTOR SHALL VERIFY LOCATIONS AND INVERTS OF ALL EXISTING SANITARY AND STORM SEWERS AND WATERMANS, PRIVATE DRAINS AND WATER SERVICES, GAS MAINS, CABLE TV, HYDRO AND TELEPHONE DUCTS ETC AT START OF CONSTRUCTION.

NO.	DATE	DESCRIPTION
0	2023-05-09	FSR SUBMISSION

REVISIONS	

LandSmith ENGINEERING & CONSULTING LTD.
 1059 UPPER JAMES STREET, SUITE 207
 HAMILTON, ON L8C 3A6
 ANDREW@LANDSMITHEC.COM
 289-775-9374

CLIENT: QIANYE PROPERTY MANAGEMENT LIMITED

MUNICIPALITY: CITY OF HAMILTON

PROJECT NAME: 253 & 259 LIMERIDGE RD W

TITLE: OVERALL SANITARY DRAINAGE AREA PLAN

SCALE: 1:1500	DATE: 2023-05-09
CHECKED BY: AS	DESIGNED BY: DH
DWG No: 220500IA	SHEET No: OVSAN

POST-DEVELOPMENT SANITARY SEWER DESIGN SHEET



DATE: May. 09, 2023 FILE No.:
 DESIGNED: DH PROJECT: 253&255 Limeridge Road W
 CHECKED: AS

Low Density = 3.405 persons per unit
 Medium Density = 2.437 persons per unit
 High Density = 1.663 persons per unit
 Industrial/Commercial = 125 ppha

q = average per capita daily flow 360
 p = unit of population density 60.00

Q(p) = peak population flow (L/s)
 Q(i) = peak extraneous flow (L/s)

P = population
 M = peaking factor (Babbitt)
 P = p x # units / 1000
 M = 5 / (P/1000)^{0.20}
 Q = (P x q x M) / 86.4

Infiltration Allowance: 0.600 L / s / ha

SHEET No.:
1 OF 1

Q(d) = peak design flow (L/s)

LOCATION				INDIVIDUAL			CUMULATIVE		PEAKING FACTOR (M)	POPULATION FLOW, Q(p) (L/s)	PEAK EXTRANEIOUS FLOW, Q(i) (L/s)	PEAK DESIGN FLOW, Q(d) (L/s)	PROPOSED SANITARY SEWER							
Area #	STREET	FROM MH	TO MH	POP	RES. AREA (ha)	Persons/Ha.	POP	TOTAL AREA (ha)					LENGTH (m)	PIPE SIZE DIAMETER (mm)	GRADE (%)	MANNING'S n	CAPACITY (L/s)	FULL FLOW VELOCITY (m/s)	ACTUAL VELOCITY (m/s)	PERCENT FULL
1	School			290	2.32	125	290	2.32												
2	Limeridge Rd W	1	2	46	0.98	47	336	3.30	5.00	7.00	1.98	8.98	100.4	250	1.00%	0.013	59.5	1.21	0.84	15.1%
3	Limeridge Rd W	2	3	96	1.16	83	432	4.46	5.00	9.00	2.68	11.68	86.5	250	0.50%	0.013	42.0	0.86	0.70	27.8%
54 PERSON INCREASE FROM PRE DEVELOPMENT CONDITIONS																				
4	Limeridge Rd W	3	4	86	1.46	59	518	5.92	5.00	10.79	3.55	14.34	104.0	250	0.50%	0.013	42.0	0.86	0.74	34.1%
5	Limeridge Rd W	4	5	64	0.95	67	582	6.87	5.00	12.13	4.12	16.25	55.6	250	0.50%	0.013	42.0	0.86	0.76	38.6%
6	Limeridge Rd W	5	6	0	0.11	0	582	6.98	5.00	12.13	4.19	16.31	56.2	250	1.00%	0.013	59.5	1.21	0.98	27.4%
7	Private Development		6	98	1.36	72	98	1.36												
8	Limeridge Rd W	6	7	157	1.25	126	837	9.59	5.00	17.44	5.75	23.19	80.3	250	1.90%	0.013	82.0	1.67	1.37	28.3%
9	Kendale Ct	8	9	302	2.29	132	302	2.29	5.00	6.29	1.37	7.67	92.0	250	0.50%	0.013	42.0	0.86	0.62	18.2%
10	Kendale Ct	9	10	164	1.31	125	466	3.60	5.00	9.71	2.16	11.87	50.6	250	0.90%	0.013	56.4	1.15	0.87	21.0%
10	Kendale Ct	10	11	0	1.31	0	466	3.60	5.00	9.71	2.16	11.87	48.3	250	3.00%	0.013	103.0	2.10	1.35	11.5%
10	Kendale Ct	11	12	0	1.31	0	466	3.60	5.00	9.71	2.16	11.87	23.9	250	0.50%	0.013	42.0	0.86	0.70	28.2%
10	Kendale Ct	12	7	0	1.31	0	466	3.60	5.00	9.71	2.16	11.87	29.0	250	0.50%	0.013	42.0	0.86	0.70	28.2%
11	Private Development		7	222	2.46	90	222	3.60												
12	Limeridge Rd W	7	13	0	0.23	0	1525	16.79	4.60	29.20	10.07	39.27	47.9	250	1.60%	0.013	75.2	1.53	1.48	52.2%
12	Limeridge Rd W	13	14	0	0.23	0	1525	16.79	4.60	29.20	10.07	39.27	38.8	250	1.30%	0.013	67.8	1.38	1.37	57.9%
12	Limeridge Rd W	14	15	0	0.23	0	1525	16.79	4.60	29.20	10.07	39.27	40.1	250	1.30%	0.013	67.8	1.38	1.37	57.9%
13	Limeridge Rd W	15	16	21	0.54	39	1546	17.33	4.58	29.52	10.40	39.92	83.1	250	0.80%	0.013	53.2	1.08	1.08	75.1%
14	Limeridge Rd W	16	17	251	5.86	43	1797	23.19	4.45	33.30	13.91	47.21	11.9	250	0.80%	0.013	53.2	1.08	1.08	88.8%
15	Limeridge Rd W	17	18	14	0.32	44	1811	23.51	4.44	33.50	14.11	47.61	41.1	250	0.80%	0.013	53.2	1.08	1.08	89.5%
16	Limeridge Rd W	18	19	11	0.41	27	1822	23.92	4.43	33.67	14.35	48.02	40.0	250	0.72%	0.013	50.5	1.03	1.03	95.2%
17	Limeridge Rd W	19	20	11	0.41	27	1833	24.33	4.43	33.83	14.60	48.43	64.4	250	0.72%	0.013	50.5	1.03	1.03	96.0%

APPENDIX 'C' – Stormwater Management

Figure S1 – Pre-Development Drainage Area

Figure S2 – External Storm Drainage Area Plan

Figure S3 – Post-Development Drainage Area

MIDUSS v2 Output Files

StormCeptor Sizing Calculation Report & Details

CB Shield Sizing Report & Details

LIMERIDGE ROAD WEST

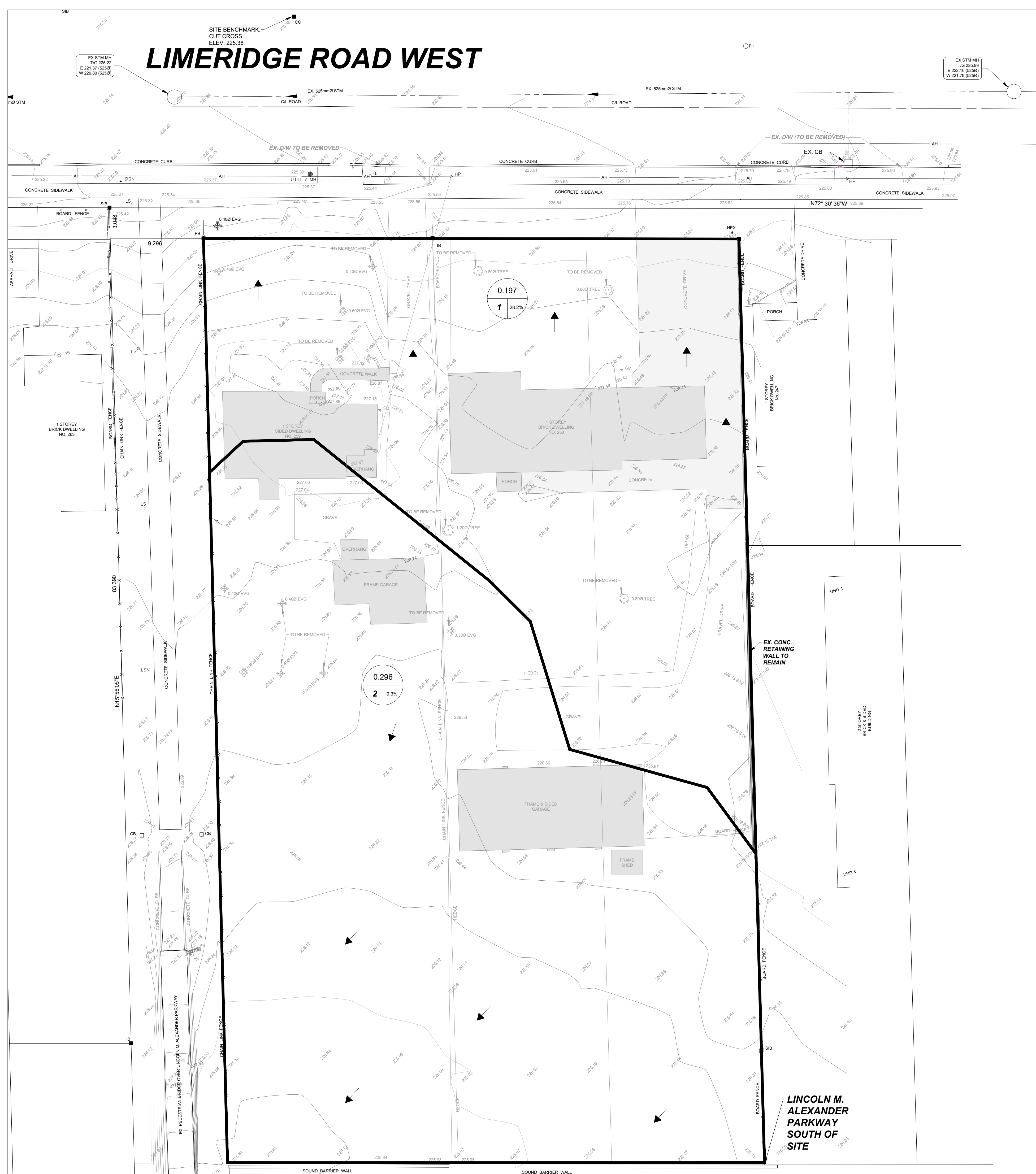

LEGEND

- DRAINAGE AREA (HECTARES)
- IMPERVIOUSNESS (%)
- DRAINAGE AREA NUMBER
- DRAINAGE AREA BOUNDARY
- OVERLAND FLOW ROUTE
- IMPERVIOUS SURFACE
- SHEET FLOW DIRECTION

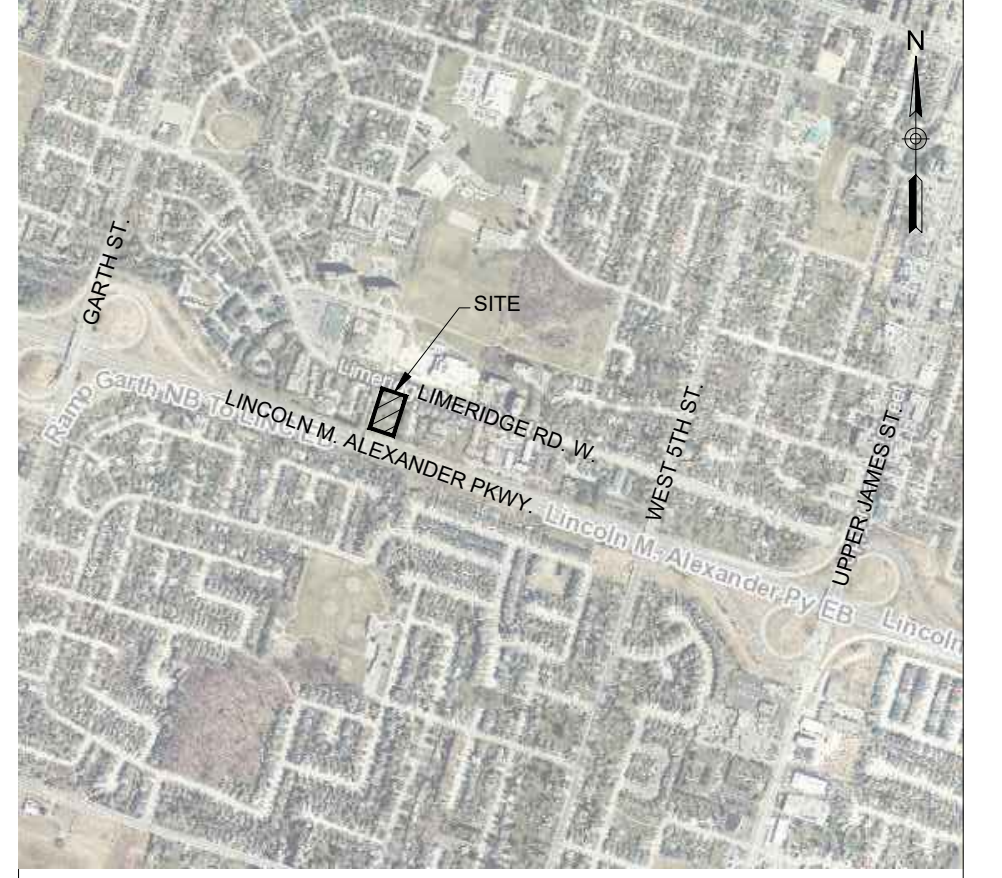

KEY PLAN N.T.S.

BENCHMARK NOTE:
ELEVATION = 225.38
MONUMENT: CUT-CROSS

BENCHMARK NOTE:
STATION: 00722091809
WEST FACE OF HOUSE NO. 355 LIMERIDGE ROAD LOCATED APPROXIMATELY 90m EAST OF THE LOT LINE BETWEEN WELLINGTON AND WENTWORTH STREETS. PLAQUE IS SET 1m NORTH IN SECOND FROM THE TOP CONCRETE BLOCK OF THE SOUTHWEST CORNER OF THE HOUSE.
NO. 967 ELEVATION 207.201

- GENERAL NOTES:**
- TENDERER SHALL SATISFY THEMSELVES AS TO THE NATURE OF THE GROUND AND BID ACCORDINGLY.
 - ALL ROCK LINE INDICATIONS SHOWN ON THE PLAN MUST BE VERIFIED BY THE CONTRACTOR.
 - CONTRACTOR SHALL VERIFY LOCATIONS AND INVERTS OF ALL EXISTING SANITARY AND STORM SEWERS AND WATERMANS, PRIVATE DRAINS AND WATER SERVICES, GAS MAINS, CABLE TV, HYDRO AND TELEPHONE DUCTS ETC AT START OF CONSTRUCTION.

NO.	DATE	DESCRIPTION
0	2022-12-16	FIRST SUBMISSION

REVISIONS

SEAL

LandSmith ENGINEERING & CONSULTING LTD.
LANDSMITH ENGINEERING & CONSULTING LTD.
UNIT 207, 1065 UPPER JAMES ST.
HAMILTON, ON L9C 3A6
ANDREW@LANDSMITHEC.COM
289-775-9374

CLIENT:
QIANYE PROPERTY MANAGEMENT LIMITED

MUNICIPALITY:
CITY OF HAMILTON

PROJECT NAME:
253-259 LIMERIDGE ROAD WEST

TITLE:
PRE-DEVELOPMENT STORM DRAINAGE AREA

SCALE:	1:200	DATE:	2022-12-16
CHECKED BY:	AS	DESIGNED BY:	AS
DWG No:	22050QIA	SHEET No:	S1

LEGEND

- 0.035 DRAINAGE AREA (HECTARES)
- 1 | 0.6 RUNOFF-COEFFICIENT
- 1 DRAINAGE AREA NUMBER
- DRAINAGE AREA BOUNDARY
- SHEET FLOW DIRECTION

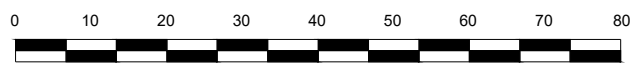
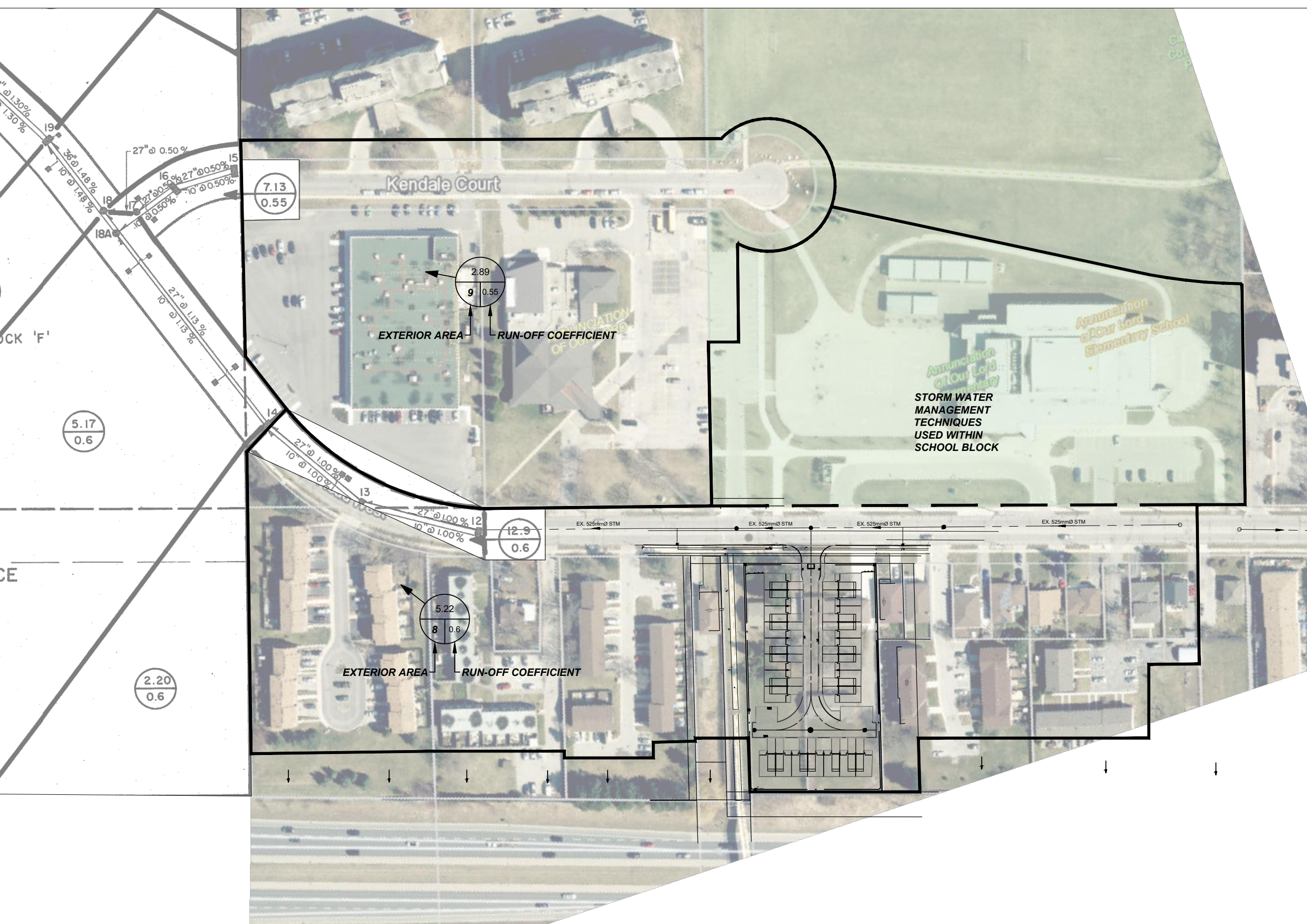
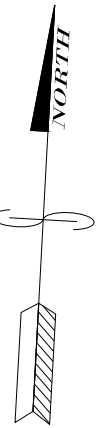

1:1500



PROJECT: 253-259 LIMERIDGE RD. W.
EXTERIOR STORM DRAINAGE AREA PLAN

FIGURE S2

LIMERIDGE ROAD WEST

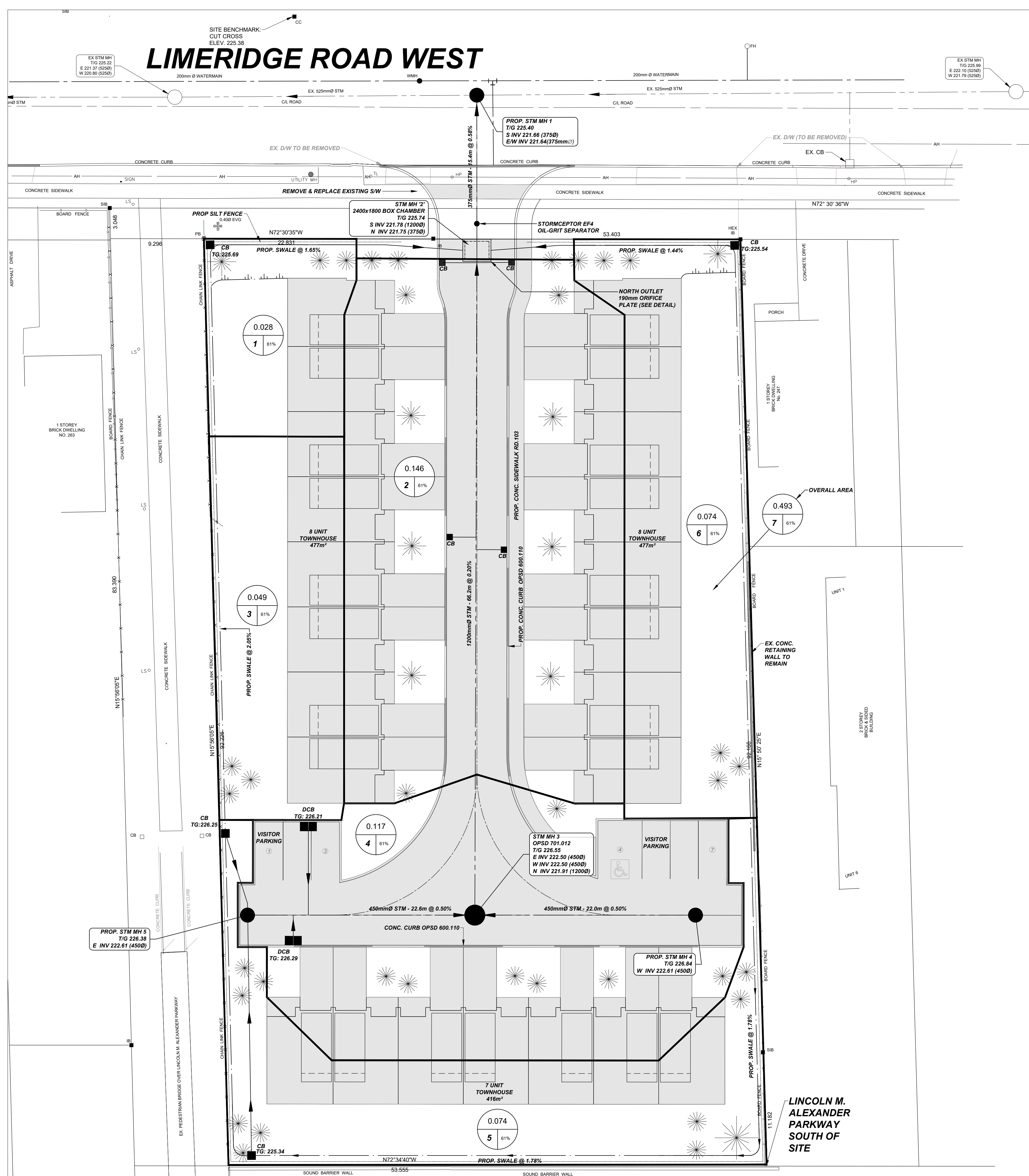

LEGEND

- DRAINAGE AREA (HECTARES)
- IMPERVIOUSNESS (%)
- DRAINAGE AREA NUMBER
- DRAINAGE AREA BOUNDARY
- OVERLAND FLOW ROUTE
- IMPERVIOUS SURFACE
- SHEET FLOW DIRECTION

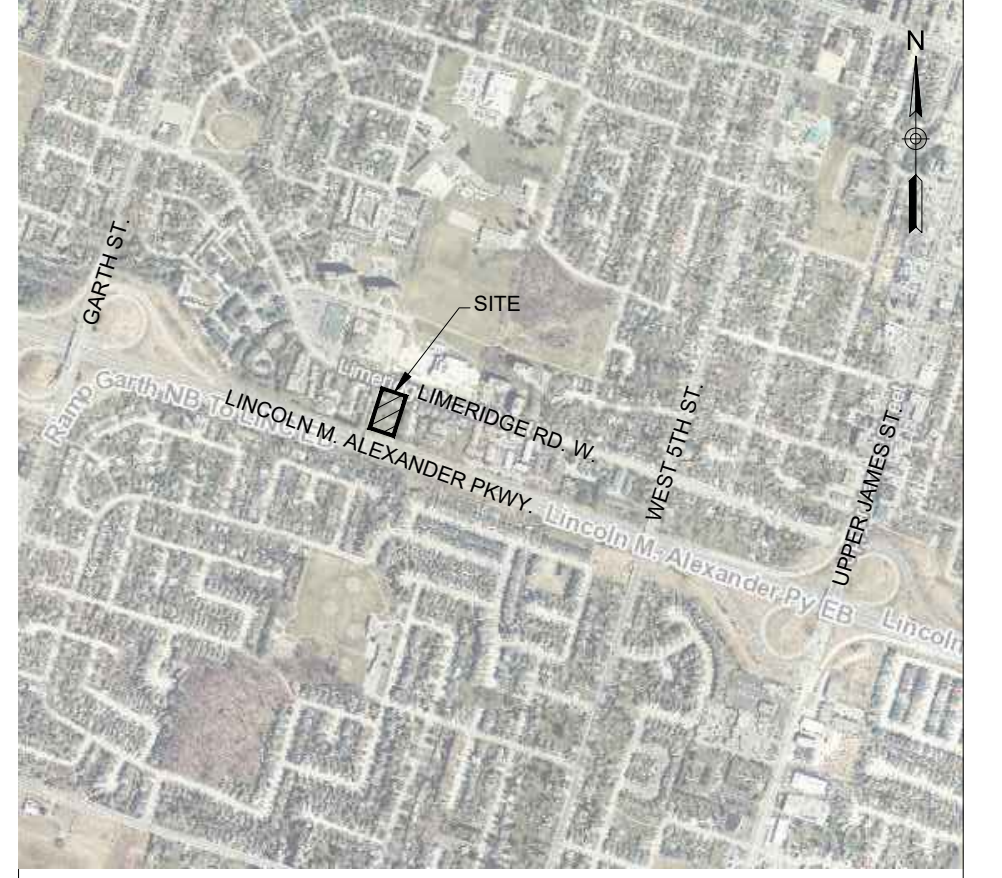

KEY PLAN N.T.S.

BENCHMARK NOTE:
 ELEVATION = 225.38
 MONUMENT: CUT-CROSS

BENCHMARK NOTE:
 STATION: 007220081809

WEST FACE OF HOUSE NO. 355 LIMERIDGE ROAD LOCATED APPROXIMATELY 90m EAST OF THE LOT LINE BETWEEN WELLINGTON AND WENTWORTH STREETS. PLAQUE IS SET 1m NORTH IN SECOND FROM THE TOP CONCRETE BLOCK OF THE SOUTHWEST CORNER OF THE HOUSE.

NO. 967 ELEVATION 207.201

- GENERAL NOTES:**
- TENDERER SHALL SATISFY THEMSELVES AS TO THE NATURE OF THE GROUND AND BID ACCORDINGLY.
 - ALL ROCK LINE INDICATIONS SHOWN ON THE PLAN MUST BE VERIFIED BY THE CONTRACTOR.
 - CONTRACTOR SHALL VERIFY LOCATIONS AND INVERTS OF ALL EXISTING SANITARY AND STORM SEWERS AND WATERMANS, PRIVATE DRAINS AND WATER SERVICES, GAS MAINS, CABLE TV, HYDRO AND TELEPHONE DUCTS ETC AT START OF CONSTRUCTION.

NO.	DATE:	DESCRIPTION:
0	2022-12-19	FIRST SUBMISSION

REVISIONS	

LANDSMITH ENGINEERING & CONSULTING LTD.
 UNIT 207, 1055 UPPER JAMES ST.
 HAMILTON, ON L9C 3A6
 ANDREW@LANDSMITHCE.COM
 289-775-8374

CLIENT:
QIANYE PROPERTY MANAGEMENT LIMITED

MUNICIPALITY:
CITY OF HAMILTON

PROJECT NAME:
253-259 LIMERIDGE ROAD WEST

TITLE:
POST-DEV. STORM DRAINAGE AREA PLAN

SCALE:	1:200	DATE:	2022-12-16
CHECKED BY:	AS	DESIGNED BY:	AS
DWG No:	220500IA	SHEET No:	S3

PRE-DEVELOPMENT

```

" MIDUSS Output ----->"
" MIDUSS version Version 2.25 rev. 473"
" MIDUSS created February 7, 2010"
" 10 Units used: ie METRIC"
" Job folder: Z:\Project Files\PROJECTS\Hamilton\
" 253 & 259 Limeridge Road West, Hamilton\SWM\2nd Submission"
" Output filename: Pre_5year.out"
" Licensee name: Andrew Smith"
" Company LandSmith Engineering & Consulting Ltd."
" Date & Time last used: 2023-05-08 at 9:32:33 AM"
" 31 TIME PARAMETERS"
" 5.000 Time Step"
" 180.000 Max. Storm length"
" 1500.000 Max. Hydrograph"
" 32 STORM Chicago storm"
" 1 Chicago storm"
" 1049.500 Coefficient A"
" 8.000 Constant B"
" 0.803 Exponent C"
" 0.500 Fraction R"
" 180.000 Duration"
" 1.000 Time step multiplier"
" Maximum intensity 103.038 mm/hr"
" Total depth 46.985 mm"
" 6 005hyd Hydrograph extension used in this file"
" 33 CATCHMENT 101"
" 1 Triangular SCS"
" 1 Equal length"
" 1 SCS method"
" 101 No description"
" 60.000 % Impervious"
" 0.197 Total Area"
" 40.000 Flow length"
" 4.000 Overland Slope"
" 0.079 Pervious Area"
" 40.000 Pervious length"
" 4.000 Pervious slope"
" 0.118 Impervious Area"
" 40.000 Impervious length"
" 4.000 Impervious slope"
" 0.250 Pervious Manning 'n'"
" 75.000 Pervious SCS Curve No."
" 0.256 Pervious Runoff coefficient"
" 0.100 Pervious Ia/S coefficient"
" 8.467 Pervious Initial abstraction"
" 0.015 Impervious Manning 'n'"
" 98.000 Impervious SCS Curve No."
" 0.878 Impervious Runoff coefficient"
" 0.100 Impervious Ia/S coefficient"
" 0.518 Impervious Initial abstraction"
" 0.034 0.000 0.000 0.000 c.m/sec"
" Catchment 101 Pervious Impervious Total Area "
" Surface Area 0.079 0.118 0.197 hectare"
" Time of concentration 17.705 2.138 4.673 minutes"
" Time to Centroid 133.399 100.806 106.113 minutes"
" Rainfall depth 46.985 46.985 46.985 mm"
" Rainfall volume 37.02 55.54 92.56 c.m"
" Rainfall losses 34.948 5.731 17.418 mm"
" Runoff depth 12.036 41.253 29.567 mm"
" Runoff volume 9.48 48.76 58.25 c.m"
" Runoff coefficient 0.256 0.878 0.629 "
" Maximum flow 0.004 0.033 0.034 c.m/sec"
" 40 HYDROGRAPH Add Runoff "
" 4 Add Runoff "
" 0.034 0.034 0.000 0.000"

```

POST-DEVELOPMENT

```

" MIDUSS Output ----->"
" MIDUSS version Version 2.25 rev. 473"
" MIDUSS created February 7, 2010"
" 10 Units used: ie METRIC"
" Job folder: Z:\Project Files\PROJECTS\Hamilton\
" 253 & 259 Limeridge Road West, Hamilton\SWM\2nd Submission\Post_Dev"
" Output filename: Post_5yr.out"
" Licensee name: Andrew Smith"
" Company LandSmith Engineering & Consulting Ltd."
" Date & Time last used: 2023-05-09 at 1:46:37 PM"
" 31 TIME PARAMETERS"
" 5.000 Time Step"
" 180.000 Max. Storm length"
" 1500.000 Max. Hydrograph"
" 32 STORM Chicago storm"
" 1 Chicago storm"
" 1049.500 Coefficient A"
" 8.000 Constant B"
" 0.803 Exponent C"
" 0.500 Fraction R"
" 180.000 Duration"
" 1.000 Time step multiplier"
" Maximum intensity 103.038 mm/hr"
" Total depth 46.985 mm"
" 6 005hyd Hydrograph extension used in this file"
" 33 CATCHMENT 101"
" 1 Triangular SCS"
" 1 Equal length"
" 1 SCS method"
" 101 No description"
" 64.000 % Impervious"
" 0.492 Total Area"
" 50.000 Flow length"
" 1.500 Overland Slope"
" 0.177 Pervious Area"
" 50.000 Pervious length"
" 1.500 Pervious slope"
" 0.315 Impervious Area"
" 50.000 Impervious length"
" 1.500 Impervious slope"
" 0.250 Pervious Manning 'n'"
" 75.000 Pervious SCS Curve No."
" 0.256 Pervious Runoff coefficient"
" 0.100 Pervious Ia/S coefficient"
" 8.467 Pervious Initial abstraction"
" 0.015 Impervious Manning 'n'"
" 98.000 Impervious SCS Curve No."
" 0.871 Impervious Runoff coefficient"
" 0.100 Impervious Ia/S coefficient"
" 0.518 Impervious Initial abstraction"
" 0.089 0.000 0.000 0.000 c.m/sec"
" Catchment 101 Pervious Impervious Total Area "
" Surface Area 0.177 0.315 0.492 hectare"
" Time of concentration 27.167 3.281 6.674 minutes"
" Time to Centroid 145.298 102.404 108.496 minutes"
" Rainfall depth 46.985 46.985 46.985 mm"
" Rainfall volume 83.22 147.94 231.16 c.m"
" Rainfall losses 34.943 6.069 16.464 mm"
" Runoff depth 12.041 40.915 30.521 mm"
" Runoff volume 21.33 128.83 150.16 c.m"
" Runoff coefficient 0.256 0.871 0.650 "
" Maximum flow 0.006 0.088 0.089 c.m/sec"
" 40 HYDROGRAPH Add Runoff "
" 4 Add Runoff "
" 0.089 0.089 0.000 0.000"
" 54 POND DESIGN"
" 0.089 Current peak flow c.m/sec"
" 0.034 Target outflow c.m/sec"
" 150.2 Hydrograph volume c.m"

```

```

"      21.  Number of stages"
"      221.750  Minimum water level  metre"
"      224.750  Maximum water level  metre"
"      221.750  Starting water level  metre"
"      0      Keep Design Data: 1 = True; 0 = False"
"      Level Discharge  Volume"
"      221.750  0.000  0.000"
"      221.900  0.00633  2.777"
"      222.050  0.01059  11.938"
"      222.200  0.01357  24.225"
"      222.350  0.01601  38.312"
"      222.500  0.01812  56.466"
"      222.650  0.02001  77.747"
"      222.800  0.02173  99.942"
"      222.950  0.02333  121.690"
"      223.100  0.02483  141.619"
"      223.250  0.02624  157.746"
"      223.400  0.02758  166.228"
"      223.550  0.02886  170.292"
"      223.700  0.03008  170.872"
"      223.850  0.03125  171.380"
"      224.000  0.03238  171.889"
"      224.150  0.03348  172.397"
"      224.300  0.03454  172.906"
"      224.450  0.03557  173.414"
"      224.600  0.03656  173.923"
"      224.750  0.03754  174.431"
"      1.  ORIFICES"
"      Orifice  Orifice  Orifice Number of"
"      invert  coefficie  diameter  orifices"
"      221.750  0.630  0.1000  1.000"
"      3.  SUPERPIPES_1"
"      1.  Type 1 is Pipe"
"      Downstream  Pipe  Pipe  Pipe  Pipe Number of"
"      Invert  Length  Width  Height  Grade %  Pipes"
"      221.750  68.200  1.500  1.500  0.200  1.000"
"      222.330  22.000  1.200  1.200  0.300  1.000"
"      222.330  22.000  1.200  1.200  0.300  1.000"
"      Peak outflow  0.019  c.m/sec"
"      Maximum level  222.563  metre"
"      Maximum storage  65.349  c.m"
"      Centroidal lag  2.455  hours"
"      0.089  0.089  0.019  0.000 c.m/sec"

```



```

"          MIDUSS Output ----->"
"          MIDUSS version                      Version 2.25 rev. 473"
"          MIDUSS created                      February 7, 2010"
"          10  Units used:                      ie METRIC"
"          Job folder:                        Z:\Project Files\PROJECTS\_Hamilton\
"          253 & 259 Limeridge Road West, Hamilton\SWM\2nd Submission\Post_Dev"
"          Output filename:                    Post_25yr.out"
"          Licensee name:                      Andrew Smith"
"          Company                            LandSmith Engineering & Consulting Ltd."
"          Date & Time last used:              2023-05-09 at 1:44:41 PM"
" 31      TIME PARAMETERS"
"          5.000  Time Step"
"          180.000 Max. Storm length"
"          1500.000 Max. Hydrograph"
" 31      TIME PARAMETERS"
"          5.000  Time Step"
"          180.000 Max. Storm length"
"          1500.000 Max. Hydrograph"
" 32      STORM Chicago storm"
"          1  Chicago storm"
"          1719.500 Coefficient A"
"          10.000  Constant B"
"          0.823  Exponent C"
"          0.500  Fraction R"
"          180.000 Duration"
"          1.000  Time step multiplier"
"          Maximum intensity                    146.101  mm/hr"
"          Total depth                          68.724  mm"
"          6  025hyd  Hydrograph extension used in this file"
" 33      CATCHMENT 101"
"          1  Triangular SCS"
"          1  Equal length"
"          1  SCS method"
"          101  No description"
"          64.000  % Impervious"
"          0.492  Total Area"
"          50.000  Flow length"
"          1.500  Overland Slope"
"          0.177  Pervious Area"
"          50.000  Pervious length"
"          1.500  Pervious slope"
"          0.315  Impervious Area"
"          50.000  Impervious length"
"          1.500  Impervious slope"
"          0.250  Pervious Manning 'n'"
"          75.000  Pervious SCS Curve No."
"          0.364  Pervious Runoff coefficient"
"          0.100  Pervious Ia/S coefficient"
"          8.467  Pervious Initial abstraction"
"          0.015  Impervious Manning 'n'"
"          98.000  Impervious SCS Curve No."
"          0.907  Impervious Runoff coefficient"
"          0.100  Impervious Ia/S coefficient"
"          0.518  Impervious Initial abstraction"
"          0.131  0.000  0.000  0.000 c.m/sec"
"          Catchment 101  Pervious  Impervious Total Area "
"          Surface Area  0.177  0.315  0.492  hectare"
"          Time of concentration  20.625  2.839  6.117  minutes"
"          Time to Centroid  134.534  100.608  106.862  minutes"
"          Rainfall depth  68.724  68.724  68.724  mm"
"          Rainfall volume  121.72  216.40  338.12  c.m"
"          Rainfall losses  43.679  6.388  19.812  mm"
"          Runoff depth  25.045  62.337  48.912  mm"
"          Runoff volume  44.36  196.29  240.65  c.m"
"          Runoff coefficient  0.364  0.907  0.712  "
"          Maximum flow  0.016  0.126  0.131  c.m/sec"
" 40      HYDROGRAPH Add Runoff "
"          4  Add Runoff "
"          0.131  0.131  0.000  0.000"
" 54      POND DESIGN"

```

```

"      0.131 Current peak flow c.m/sec"
"      0.034 Target outflow c.m/sec"
"      240.6 Hydrograph volume c.m"
"      21. Number of stages"
"      221.750 Minimum water level metre"
"      224.750 Maximum water level metre"
"      221.750 Starting water level metre"
"      0 Keep Design Data: 1 = True; 0 = False"
"      Level Discharge Volume"
"      221.750 0.000 0.000"
"      221.900 0.00633 2.777"
"      222.050 0.01059 11.938"
"      222.200 0.01357 24.225"
"      222.350 0.01601 38.312"
"      222.500 0.01812 56.466"
"      222.650 0.02001 77.747"
"      222.800 0.02173 99.942"
"      222.950 0.02333 121.690"
"      223.100 0.02483 141.619"
"      223.250 0.02624 157.746"
"      223.400 0.02758 166.228"
"      223.550 0.02886 170.292"
"      223.700 0.03008 170.872"
"      223.850 0.03125 171.380"
"      224.000 0.03238 171.889"
"      224.150 0.03348 172.397"
"      224.300 0.03454 172.906"
"      224.450 0.03557 173.414"
"      224.600 0.03656 173.923"
"      224.750 0.03754 174.431"
"      1. ORIFICES"
"      Orifice Orifice Orifice Number of"
"      invert coefficient diameter orifices"
"      221.750 0.630 0.1000 1.000"
"      3. SUPERPIPES_1"
"      1. Type 1 is Pipe"
"      Downstream Pipe Pipe Pipe Pipe Number of"
"      Invert Length Width Height Grade % Pipes"
"      221.750 68.200 1.500 1.500 0.200 1.000"
"      222.330 22.000 1.200 1.200 0.300 1.000"
"      222.330 22.000 1.200 1.200 0.300 1.000"
"      Peak outflow 0.023 c.m/sec"
"      Maximum level 222.962 metre"
"      Maximum storage 123.304 c.m"
"      Centroidal lag 2.765 hours"
"      0.131 0.131 0.023 0.000 c.m/sec"

```

```

"          MIDUSS Output ----->"
"          MIDUSS version                      Version 2.25 rev. 473"
"          MIDUSS created                      February 7, 2010"
"          10  Units used:                      ie METRIC"
"          Job folder:                        Z:\Project Files\PROJECTS\_Hamilton\
"          253 & 259 Limeridge Road West, Hamilton\SWM\2nd Submission\Post_Dev"
"          Output filename:                   CHECK_2.out"
"          Licensee name:                     Andrew Smith"
"          Company                           LandSmith Engineering & Consulting Ltd."
"          Date & Time last used:             2023-05-09 at 1:41:27 PM"
" 31      TIME PARAMETERS"
"          5.000  Time Step"
"          180.000 Max. Storm length"
"          1500.000 Max. Hydrograph"
" 32      STORM Chicago storm"
"          1  Chicago storm"
"          2317.400 Coefficient A"
"          11.000  Constant B"
"          0.836  Exponent C"
"          0.500  Fraction R"
"          180.000 Duration"
"          1.000  Time step multiplier"
"          Maximum intensity          181.813  mm/hr"
"          Total depth                86.135  mm"
"          6  100hyd Hydrograph extension used in this file"
" 33      CATCHMENT 101"
"          1  Triangular SCS"
"          1  Equal length"
"          1  SCS method"
"          101  No description"
"          64.000 % Impervious"
"          0.492 Total Area"
"          50.000 Flow length"
"          1.500 Overland Slope"
"          0.177 Pervious Area"
"          50.000 Pervious length"
"          1.500 Pervious slope"
"          0.315 Impervious Area"
"          50.000 Impervious length"
"          1.500 Impervious slope"
"          0.250 Pervious Manning 'n'"
"          75.000 Pervious SCS Curve No."
"          0.431 Pervious Runoff coefficient"
"          0.100 Pervious Ia/S coefficient"
"          8.467 Pervious Initial abstraction"
"          0.015 Impervious Manning 'n'"
"          98.000 Impervious SCS Curve No."
"          0.920 Impervious Runoff coefficient"
"          0.100 Impervious Ia/S coefficient"
"          0.518 Impervious Initial abstraction"
"          0.165 0.000 0.000 0.000 c.m/sec"
"          Catchment 101 Pervious Impervious Total Area "
"          Surface Area 0.177 0.315 0.492 hectare"
"          Time of concentration 17.735 2.596 5.752 minutes"
"          Time to Centroid 129.506 99.684 105.901 minutes"
"          Rainfall depth 86.135 86.135 86.135 mm"
"          Rainfall volume 152.56 271.22 423.78 c.m"
"          Rainfall losses 49.021 6.857 22.036 mm"
"          Runoff depth 37.114 79.277 64.098 mm"
"          Runoff volume 65.74 249.63 315.36 c.m"
"          Runoff coefficient 0.431 0.920 0.744 "
"          Maximum flow 0.027 0.156 0.165 c.m/sec"
" 40      HYDROGRAPH Add Runoff "
"          4  Add Runoff "
"          0.165 0.165 0.000 0.000"
" 54      POND DESIGN"
"          0.165 Current peak flow c.m/sec"
"          0.034 Target outflow c.m/sec"
"          315.4 Hydrograph volume c.m"

```



```

"      21.  Number of stages"
"      221.750  Minimum water level  metre"
"      224.750  Maximum water level  metre"
"      221.750  Starting water level  metre"
"      0      Keep Design Data: 1 = True; 0 = False"
"      Level Discharge  Volume"
"      221.750  0.000  0.000"
"      221.900  0.00734  2.777"
"      222.050  0.01263  11.938"
"      222.200  0.01628  24.225"
"      222.350  0.01925  38.320"
"      222.500  0.02181  56.797"
"      222.650  0.02411  78.178"
"      222.800  0.02621  100.300"
"      222.950  0.02815  121.739"
"      223.100  0.02996  141.014"
"      223.250  0.03168  155.930"
"      223.400  0.03330  161.852"
"      223.550  0.03485  162.370"
"      223.700  0.03633  162.879"
"      223.850  0.03775  163.387"
"      224.000  0.03913  163.896"
"      224.150  0.04045  164.404"
"      224.300  0.04173  164.913"
"      224.450  0.04298  165.421"
"      224.600  0.04419  165.930"
"      224.750  0.04537  166.438"
"      1.  ORIFICES"
"      Orifice  Orifice  Orifice Number of"
"      invert  coefficie  diameter  orifices"
"      221.750  0.630  0.1100  1.000"
"      3.  SUPERPIPES_1"
"      1.  Type 1 is Pipe"
"      Downstream  Pipe  Pipe  Pipe  Pipe Number of"
"      Invert  Length  Width  Height  Grade %  Pipes"
"      221.750  68.200  1.500  1.500  0.200  1.000"
"      222.330  22.000  1.050  1.050  0.200  1.000"
"      222.330  25.800  1.050  1.050  0.200  1.000"
"      Peak outflow  0.033  c.m/sec"
"      Maximum level  223.393  metre"
"      Maximum storage  161.575  c.m"
"      Centroidal lag  2.717  hours"
"      0.165  0.165  0.033  0.000 c.m/sec"

```

Stormceptor® EF Sizing Report

**STORMCEPTOR®
ESTIMATED NET ANNUAL SEDIMENT (TSS) LOAD REDUCTION**

12/19/2022

Province:	Ontario
City:	Hamilton
Nearest Rainfall Station:	HAMILTON RBG CS
Climate Station Id:	6153301
Years of Rainfall Data:	20

Project Name:	253 & 259 Limeridge Road West
Project Number:	22050Qia
Designer Name:	Andrew Smith
Designer Company:	LandSmith Engineering & Consulting Ltd.
Designer Email:	andrew@landsmithec.com
Designer Phone:	289-309-3632
EOR Name:	
EOR Company:	
EOR Email:	
EOR Phone:	

Site Name:	
------------	--

Drainage Area (ha):	0.49
% Imperviousness:	45.00

Runoff Coefficient 'c': 0.57

Particle Size Distribution:	CA ETV
Target TSS Removal (%):	60.0

Required Water Quality Runoff Volume Capture (%):	90.00
Estimated Water Quality Flow Rate (L/s):	8.74
Oil / Fuel Spill Risk Site?	No
Upstream Flow Control?	Yes
Upstream Orifice Control Flow Rate to Stormceptor (L/s):	85.00
Peak Conveyance (maximum) Flow Rate (L/s):	
Site Sediment Transport Rate (kg/ha/yr):	480.00
Estimated Average Annual Sediment Load (kg/yr):	134.06

Net Annual Sediment (TSS) Load Reduction Sizing Summary	
Stormceptor Model	TSS Removal Provided (%)
EF4	61
EF6	65
EF8	68
EF10	69
EF12	70

Recommended Stormceptor EF Model: EF4
Estimated Net Annual Sediment (TSS) Load Reduction (%): 61
Water Quality Runoff Volume Capture (%): > 90



Stormceptor® EF Sizing Report

THIRD-PARTY TESTING AND VERIFICATION

► **Stormceptor® EF and Stormceptor® EFO** are the latest evolutions in the Stormceptor® oil-grit separator (OGS) technology series, and are designed to remove a wide variety of pollutants from stormwater and snowmelt runoff. These technologies have been third-party tested in accordance with the Canadian ETV **Procedure for Laboratory Testing of Oil-Grit Separators** and performance has been third-party verified in accordance with the **ISO 14034 Environmental Technology Verification (ETV)** protocol.

PERFORMANCE

► **Stormceptor® EF and EFO** remove stormwater pollutants through gravity separation and floatation, and feature a patent-pending design that generates positive removal of total suspended solids (TSS) throughout each storm event, including high-intensity storms. Captured pollutants include sediment, free oils, and sediment-bound pollutants such as nutrients, heavy metals, and petroleum hydrocarbons. Stormceptor is sized to remove a high level of TSS from the frequent rainfall events that contribute the vast majority of annual runoff volume and pollutant load. The technology incorporates an internal bypass to convey excessive stormwater flows from high-intensity storms through the device without resuspension and washout (scour) of previously captured pollutants. Proper routine maintenance ensures high pollutant removal performance and protection of downstream waterways.

PARTICLE SIZE DISTRIBUTION (PSD)

► The **Canadian ETV PSD** shown in the table below was used, or in part, for this sizing. This is the identical PSD that is referenced in the Canadian ETV **Procedure for Laboratory Testing of Oil-Grit Separators** for both sediment removal testing and scour testing. The Canadian ETV PSD contains a wide range of particle sizes in the sand and silt fractions, and is considered reasonably representative of the particle size fractions found in typical urban stormwater runoff.

Particle Size (µm)	Percent Less Than	Particle Size Fraction (µm)	Percent
1000	100	500-1000	5
500	95	250-500	5
250	90	150-250	15
150	75	100-150	15
100	60	75-100	10
75	50	50-75	5
50	45	20-50	10
20	35	8-20	15
8	20	5-8	10
5	10	2-5	5
2	5	<2	5

Stormceptor®EF Sizing Report

Upstream Flow Controlled Results

Rainfall Intensity (mm / hr)	Percent Rainfall Volume (%)	Cumulative Rainfall Volume (%)	Flow Rate (L/s)	Flow Rate (L/min)	Surface Loading Rate (L/min/m ²)	Removal Efficiency (%)	Incremental Removal (%)	Cumulative Removal (%)
0.5	9.1	9.1	0.39	23.0	19.0	70	6.4	6.4
1	19.0	28.0	0.78	47.0	39.0	70	13.4	19.7
2	15.5	43.5	1.55	93.0	78.0	66	10.2	29.9
3	12.1	55.6	2.33	140.0	116.0	62	7.4	37.4
4	8.2	63.8	3.11	186.0	155.0	58	4.8	42.1
5	6.5	70.4	3.88	233.0	194.0	55	3.6	45.7
6	5.5	75.9	4.66	280.0	233.0	53	2.9	48.6
7	3.2	79.0	5.44	326.0	272.0	52	1.6	50.3
8	2.9	81.9	6.21	373.0	311.0	51	1.5	51.7
9	3.2	85.2	6.99	419.0	349.0	50	1.6	53.3
10	2.7	87.9	7.76	466.0	388.0	49	1.3	54.6
11	1.7	89.6	8.54	512.0	427.0	48	0.8	55.5
12	1.5	91.1	9.32	559.0	466.0	47	0.7	56.2
13	1.1	92.2	10.09	606.0	505.0	47	0.5	56.7
14	0.9	93.1	10.87	652.0	544.0	47	0.4	57.1
15	1.4	94.5	11.65	699.0	582.0	46	0.6	57.8
16	0.6	95.1	12.42	745.0	621.0	46	0.3	58.0
17	0.5	95.6	13.20	792.0	660.0	46	0.2	58.3
18	0.3	95.9	13.98	839.0	699.0	46	0.2	58.4
19	0.5	96.4	14.75	885.0	738.0	45	0.2	58.7
20	0.4	96.8	15.53	932.0	776.0	45	0.2	58.8
21	0.8	97.6	16.31	978.0	815.0	45	0.4	59.2
22	0.2	97.8	17.08	1025.0	854.0	45	0.1	59.3
23	0.4	98.2	17.86	1072.0	893.0	45	0.2	59.5
24	0.7	98.9	18.63	1118.0	932.0	44	0.3	59.8
25	1.1	100.0	19.41	1165.0	971.0	44	0.5	60.2
30	0.7	100.7	23.29	1398.0	1165.0	46	0.3	60.6
35	0.3	101.1	27.18	1631.0	1359.0	48	0.2	60.7
40	-1.1	100.0	31.06	1863.0	1553.0	44	N/A	60.3
45	0.0	100.0	34.94	2096.0	1747.0	39	0.0	60.3
Estimated Net Annual Sediment (TSS) Load Reduction =								60 %

Climate Station ID: 6153301 Years of Rainfall Data: 20



Stormceptor® EF Sizing Report

RAINFALL DATA FROM HAMILTON RBG CS RAINFALL STATION

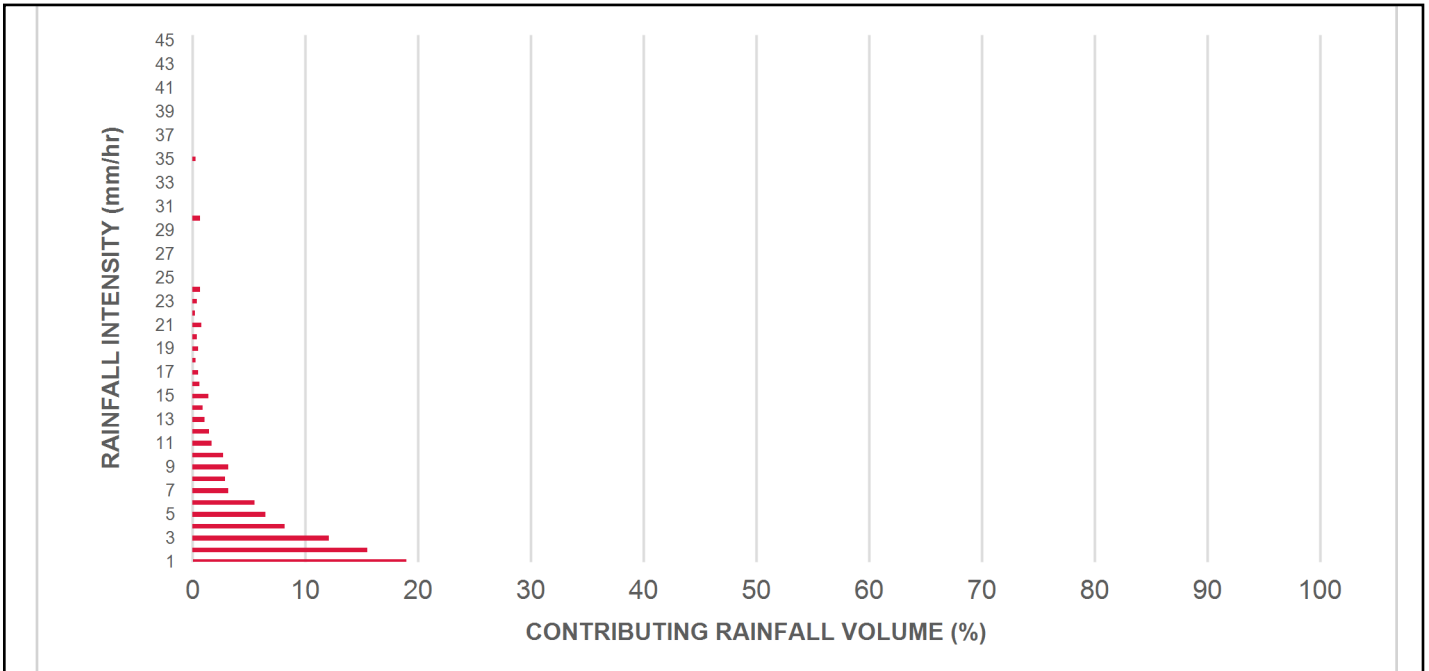

INCREMENTAL AND CUMULATIVE TSS REMOVAL FOR THE RECOMMENDED STORMCEPTOR® MODEL

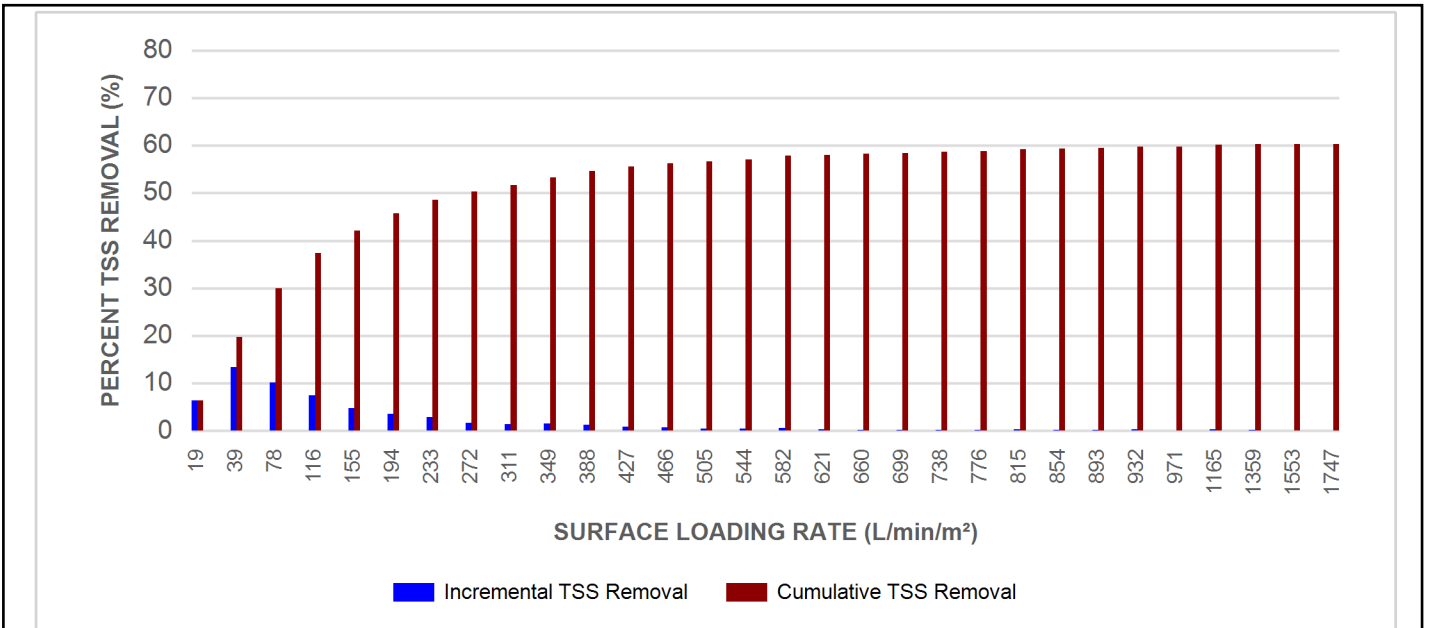

Stormceptor® **EF** Sizing Report

Maximum Pipe Diameter / Peak Conveyance

Stormceptor EF / EFO	Model Diameter		Min Angle Inlet / Outlet Pipes	Max Inlet Pipe Diameter		Max Outlet Pipe Diameter		Peak Conveyance Flow Rate	
	(m)	(ft)		(mm)	(in)	(mm)	(in)	(L/s)	(cfs)
EF4 / EFO4	1.2	4	90	609	24	609	24	425	15
EF6 / EFO6	1.8	6	90	914	36	914	36	990	35
EF8 / EFO8	2.4	8	90	1219	48	1219	48	1700	60
EF10 / EFO10	3.0	10	90	1828	72	1828	72	2830	100
EF12 / EFO12	3.6	12	90	1828	72	1828	72	2830	100

SCOUR PREVENTION AND ONLINE CONFIGURATION

► Stormceptor® EF and EFO feature an internal bypass and superior scour prevention technology that have been demonstrated in third-party testing according to the scour testing provisions of the Canadian ETV **Procedure for Laboratory Testing of Oil-Grit Separators**, and the exceptional scour test performance has been third-party verified in accordance with the ISO 14034 ETV protocol. As a result, Stormceptor EF and EFO are approved for online installation, eliminating the need for costly additional bypass structures, piping, and installation expense.

DESIGN FLEXIBILITY

► Stormceptor® EF and EFO offers design flexibility in one simplified platform, accepting stormwater flow from a single inlet pipe or multiple inlet pipes, and/or surface runoff through an inlet grate. The device can also serve as a junction structure, accommodate a 90-degree inlet-to-outlet bend angle, and can be modified to ensure performance in submerged conditions.

OIL CAPTURE AND RETENTION

► While Stormceptor® EF will capture and retain oil from dry weather spills and low intensity runoff, Stormceptor® EFO has demonstrated superior oil capture and greater than 99% oil retention in third-party testing according to the light liquid re-entrainment testing provisions of the Canadian ETV **Procedure for Laboratory Testing of Oil-Grit Separators**. Stormceptor EFO is recommended for sites where oil capture and retention is a requirement.

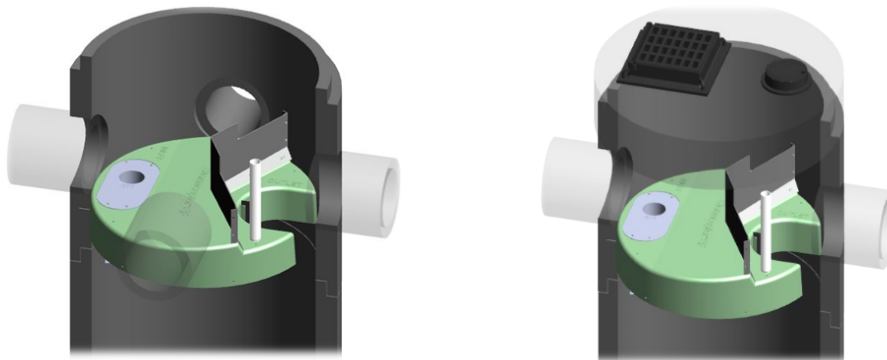

Stormceptor® EF Sizing Report

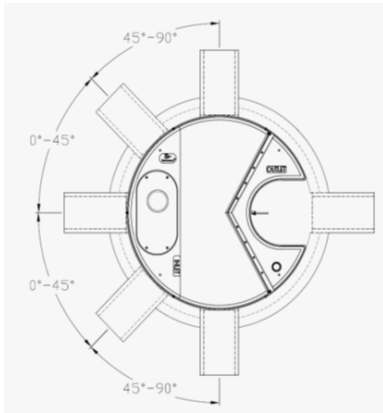

INLET-TO-OUTLET DROP

Elevation differential between inlet and outlet pipe inverts is dictated by the angle at which the inlet pipe(s) enters the unit.

0° - 45° : The inlet pipe is 1-inch (25mm) higher than the outlet pipe.

45° - 90° : The inlet pipe is 2-inches (50mm) higher than the outlet pipe.

HEAD LOSS

The head loss through Stormceptor EF is similar to that of a 60-degree bend structure. The applicable K value for calculating minor losses through the unit is 1.1.

For submerged conditions the applicable K value is 3.0.

Pollutant Capacity

Stormceptor EF / EFO	Model Diameter		Depth (Outlet Pipe Invert to Sump Floor)		Oil Volume		Recommended Sediment Maintenance Depth *		Maximum Sediment Volume *		Maximum Sediment Mass **	
	(m)	(ft)	(m)	(ft)	(L)	(Gal)	(mm)	(in)	(L)	(ft³)	(kg)	(lb)
EF4 / EFO4	1.2	4	1.52	5.0	265	70	203	8	1190	42	1904	5250
EF6 / EFO6	1.8	6	1.93	6.3	610	160	305	12	3470	123	5552	15375
EF8 / EFO8	2.4	8	2.59	8.5	1070	280	610	24	8780	310	14048	38750
EF10 / EFO10	3.0	10	3.25	10.7	1670	440	610	24	17790	628	28464	78500
EF12 / EFO12	3.6	12	3.89	12.8	2475	655	610	24	31220	1103	49952	137875

*Increased sump depth may be added to increase sediment storage capacity

** Average density of wet packed sediment in sump = 1.6 kg/L (100 lb/ft³)

Feature	Benefit	Feature Appeals To
Patent-pending enhanced flow treatment and scour prevention technology	Superior, verified third-party performance	Regulator, Specifying & Design Engineer
Third-party verified light liquid capture and retention for EFO version	Proven performance for fuel/oil hotspot locations	Regulator, Specifying & Design Engineer, Site Owner
Functions as bend, junction or inlet structure	Design flexibility	Specifying & Design Engineer
Minimal drop between inlet and outlet	Site installation ease	Contractor
Large diameter outlet riser for inspection and maintenance	Easy maintenance access from grade	Maintenance Contractor & Site Owner

STANDARD STORMCEPTOR EF/EFO DRAWINGS

For standard details, please visit <http://www.imbriumsystems.com/stormwater-treatment-solutions/stormceptor-ef>

STANDARD STORMCEPTOR EF/EFO SPECIFICATION

For specifications, please visit <http://www.imbriumsystems.com/stormwater-treatment-solutions/stormceptor-ef>

Stormceptor® EF Sizing Report

**Table of TSS Removal vs Surface Loading Rate Based on Third-Party Test Results
Stormceptor® EF**

SLR (L/min/m ²)	TSS % REMOVAL	SLR (L/min/m ²)	TSS % REMOVAL	SLR (L/min/m ²)	TSS % REMOVAL	SLR (L/min/m ²)	TSS % REMOVAL
1	70	660	46	1320	48	1980	35
30	70	690	46	1350	48	2010	34
60	67	720	45	1380	49	2040	34
90	63	750	45	1410	49	2070	33
120	61	780	45	1440	48	2100	33
150	58	810	45	1470	47	2130	32
180	56	840	45	1500	46	2160	32
210	54	870	45	1530	45	2190	31
240	53	900	45	1560	44	2220	31
270	52	930	44	1590	43	2250	30
300	51	960	44	1620	42	2280	30
330	50	990	44	1650	42	2310	30
360	49	1020	44	1680	41	2340	29
390	48	1050	45	1710	40	2370	29
420	48	1080	45	1740	39	2400	29
450	48	1110	45	1770	39	2430	28
480	47	1140	46	1800	38	2460	28
510	47	1170	46	1830	37	2490	28
540	47	1200	47	1860	37	2520	27
570	46	1230	47	1890	36	2550	27
600	46	1260	47	1920	36	2580	27
630	46	1290	48	1950	35		



Stormceptor® **EF** Sizing Report

**STANDARD PERFORMANCE SPECIFICATION FOR
“OIL GRIT SEPARATOR” (OGS) STORMWATER QUALITY TREATMENT DEVICE**

PART 1 – GENERAL

1.1 WORK INCLUDED

This section specifies requirements for selecting, sizing, and designing an underground Oil Grit Separator (OGS) device for stormwater quality treatment, with third-party testing results and a Statement of Verification in accordance with ISO 14034 Environmental Management – Environmental Technology Verification (ETV).

1.2 REFERENCE STANDARDS & PROCEDURES

ISO 14034:2016 Environmental management – Environmental technology verification (ETV)

Canadian Environmental Technology Verification (ETV) Program’s **Procedure for Laboratory Testing of Oil-Grit Separators.**

1.3 SUBMITTALS

1.3.1 All submittals, including sizing reports & shop drawings, shall be submitted upon request with each order to the contractor then forwarded to the Engineer of Record for review and acceptance. Shop drawings shall detail all OGS components, elevations, and sequence of construction.

1.3.2 Alternative devices shall have features identical to or greater than the specified device, including: treatment chamber diameter, treatment chamber wet volume, sediment storage volume, and oil storage volume.

1.3.3 Unless directed otherwise by the Engineer of Record, OGS stormwater quality treatment product substitutions or alternatives submitted within ten days prior to project bid shall not be accepted. All alternatives or substitutions submitted shall be signed and sealed by a local registered Professional Engineer, based on the exact same criteria detailed in Section 3, in entirety, subject to review and approval by the Engineer of Record.

PART 2 – PRODUCTS

2.1 OGS POLLUTANT STORAGE

The OGS device shall include a sump for sediment storage, and a protected volume for the capture and storage of petroleum hydrocarbons and buoyant gross pollutants. The **minimum** sediment & petroleum hydrocarbon storage capacity shall be as follows:

2.1.1	4 ft (1219 mm) Diameter OGS Units:	1.19 m ³ sediment / 265 L oil
	6 ft (1829 mm) Diameter OGS Units:	3.48 m ³ sediment / 609 L oil
	8 ft (2438 mm) Diameter OGS Units:	8.78 m ³ sediment / 1,071 L oil
	10 ft (3048 mm) Diameter OGS Units:	17.78 m ³ sediment / 1,673 L oil
	12 ft (3657 mm) Diameter OGS Units:	31.23 m ³ sediment / 2,476 L oil

PART 3 – PERFORMANCE & DESIGN

3.1 GENERAL



Stormceptor®EF Sizing Report

The OGS stormwater quality treatment device shall be verified in accordance with ISO 14034:2016 Environmental management – Environmental technology verification (ETV). The OGS stormwater quality treatment device shall remove oil, sediment and gross pollutants from stormwater runoff during frequent wet weather events, and retain these pollutants during less frequent high flow wet weather events below the insert within the OGS for later removal during maintenance. The Manufacturer shall have at least ten (10) years of local experience, history and success in engineering design, manufacturing and production and supply of OGS stormwater quality treatment device systems, acceptable to the Engineer of Record.

3.2 SIZING METHODOLOGY

The OGS device shall be engineered, designed and sized to provide stormwater quality treatment based on treating a minimum of 90 percent of the average annual runoff volume and a minimum removal of an annual average 60% of the sediment (TSS) load based on the Particle Size Distribution (PSD) specified in the sizing report for the specified device. Sizing of the OGS shall be determined by use of a minimum ten (10) years of local historical rainfall data provided by Environment Canada. Sizing shall also be determined by use of the sediment removal performance data derived from the ISO 14034 ETV third-party verified laboratory testing data from testing conducted in accordance with the Canadian ETV protocol Procedure for Laboratory Testing of Oil-Grit Separators, as follows:

3.2.1 Sediment removal efficiency for a given surface loading rate and its associated flow rate shall be based on sediment removal efficiency demonstrated at the seven (7) tested surface loading rates specified in the protocol, ranging 40 L/min/m² to 1400 L/min/m², and as stated in the ISO 14034 ETV Verification Statement for the OGS device.

3.2.2 Sediment removal efficiency for surface loading rates between 40 L/min/m² and 1400 L/min/m² shall be based on linear interpolation of data between consecutive tested surface loading rates.

3.2.3 Sediment removal efficiency for surface loading rates less than the lowest tested surface loading rate of 40 L/min/m² shall be assumed to be identical to the sediment removal efficiency at 40 L/min/m². No extrapolation shall be allowed that results in a sediment removal efficiency that is greater than that demonstrated at 40 L/min/m².

3.2.4 Sediment removal efficiency for surface loading rates greater than the highest tested surface loading rate of 1400 L/min/m² shall assume zero sediment removal for the portion of flow that exceeds 1400 L/min/m², and shall be calculated using a simple proportioning formula, with 1400 L/min/m² in the numerator and the higher surface loading rate in the denominator, and multiplying the resulting fraction times the sediment removal efficiency at 1400 L/min/m².

The OGS device shall also have sufficient annual sediment storage capacity as specified and calculated in Section 2.1.

3.3 CANADIAN ETV or ISO 14034 ETV VERIFICATION OF SCOUR TESTING

The OGS device shall have Canadian ETV or ISO 14034 ETV Verification of third-party scour testing conducted in accordance with the Canadian ETV Program's **Procedure for Laboratory Testing of Oil-Grit Separators**.

3.3.1 To be acceptable for on-line installation, the OGS device must demonstrate an average scour test effluent concentration less than 10 mg/L at each surface loading rate tested, up to and including 2600 L/min/m².

Appendix A

Average Annual Sediment Removal Rates (%) using a CB Shield (based on ETV Sediment - 1 to 1000 micron Particle Size Distribution)						
Area to CB (ha)	Imperviousness¹ (%)					
	20%	35%	50%	65%	80%	100%
0.02	57%	57%	57%	57%	56%	56%
0.05	56%	56%	56%	55%	55%	54%
0.10	56%	55%	54%	53%	52%	51%
0.20	54%	53%	51%	49%	48%	46%
0.30	53%	50%	48%	46%	45%	43%
0.40	51%	48%	46%	44%	42%	40%
0.50	50%	47%	44%	42%	40%	38%
0.60	49%	45%	43%	40%	39%	36%

Notes:

1. Runoff Coefficient 'C' is approximately equal to 0.05 + 0.9*Impervious Fraction.
2. Above chart is based on long term continuous hydrologic analysis of Toronto, Ontario (Bloor St) rainfall data.
3. Assumes 0.6 m sump in CB and that maintenance is performed (i.e. CB cleaning) when required by sediment/pollutant build-up or otherwise.
4. See accompanying chart for suggested maintenance scheduling - AND - get CB Shield Inc. to monitor it for you in field.
5. Sediment/Pollutant removal rates based on third party certified laboratory testing using ETV sediment (PSD analysis available on request).
6. See additional discussion regarding scour protection from CB Shield during more infrequent runoff events.

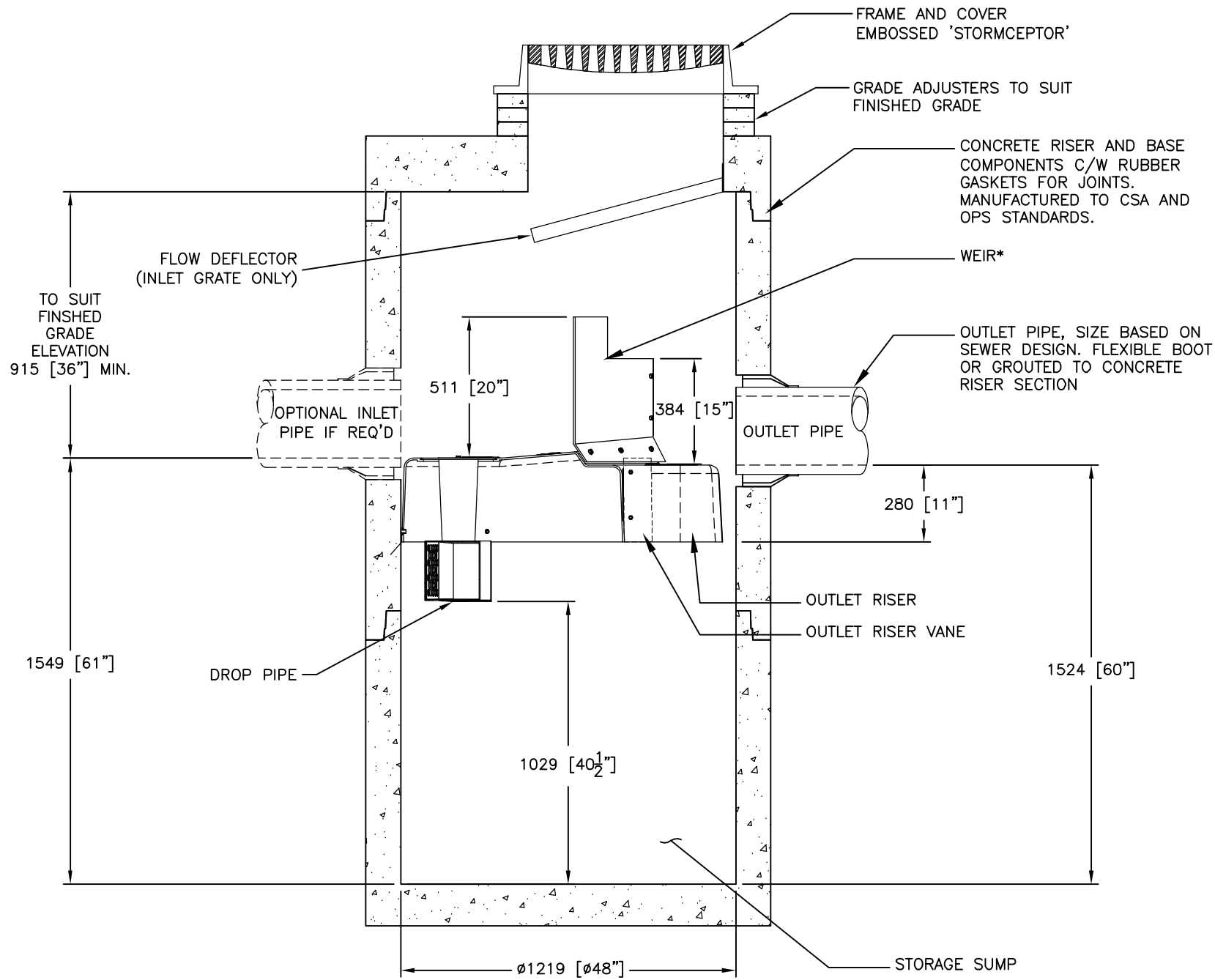

SECTION VIEW

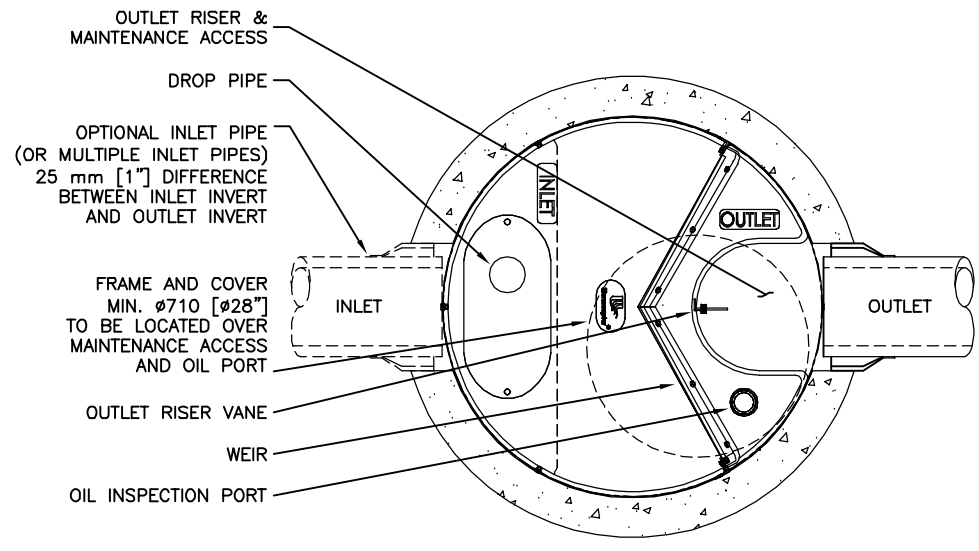

PLAN VIEW (STANDARD)

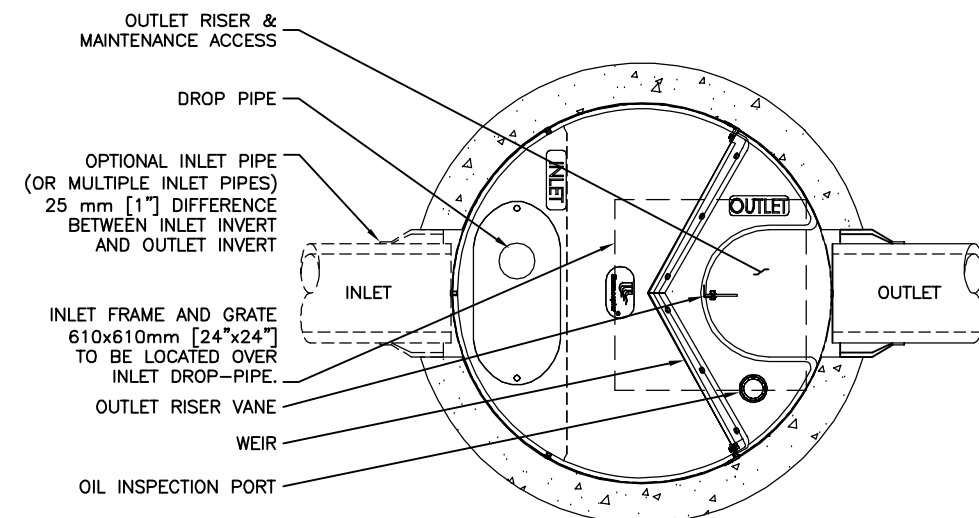

PLAN VIEW (INLET TOP)

FOR SITE SPECIFIC DRAWINGS PLEASE CONTACT YOUR LOCAL STORMCEPTOR REPRESENTATIVE. SITE SPECIFIC DRAWINGS ARE BASED ON THE BEST AVAILABLE INFORMATION AT THE TIME. SOME FIELD REVISIONS TO THE SYSTEM LOCATION OR CONNECTION PIPING MAY BE NECESSARY BASED ON AVAILABLE SPACE OR SITE CONFIGURATION REVISIONS. ELEVATIONS SHOULD BE MAINTAINED EXCEPT WHERE NOTED ON BYPASS STRUCTURE (IF REQUIRED).

GENERAL NOTES:

- * MAXIMUM SURFACE LOADING RATE (SLR) INTO LOWER CHAMBER THROUGH DROP PIPE IS 1135 L/min/m² (27.9 gpm/ft²) FOR STORMCEPTOR EF4 AND 535 L/min/m² (13.1 gpm/ft²) FOR STORMCEPTOR EFO4 (OIL CAPTURE CONFIGURATION). WEIR HEIGHT IS 150 mm (6 INCH) FOR EF04.
- 1. ALL DIMENSIONS INDICATED ARE IN MILLIMETERS (INCHES) UNLESS OTHERWISE SPECIFIED.
- 2. STORMCEPTOR STRUCTURE INLET AND OUTLET PIPE SIZE AND ORIENTATION SHOWN FOR INFORMATIONAL PURPOSES ONLY.
- 3. UNLESS OTHERWISE NOTED, BYPASS INFRASTRUCTURE, SUCH AS ALL UPSTREAM DIVERSION STRUCTURES, CONNECTING STRUCTURES, OR PIPE CONDUITS CONNECTING TO COMPLETE THE STORMCEPTOR SYSTEM SHALL BE PROVIDED AND ADDRESSED SEPARATELY.
- 4. DRAWING FOR INFORMATION PURPOSES ONLY. REFER TO ENGINEER'S SITE/UTILITY PLAN FOR STRUCTURE ORIENTATION.
- 5. NO PRODUCT SUBSTITUTIONS SHALL BE ACCEPTED UNLESS SUBMITTED 10 DAYS PRIOR TO PROJECT BID DATE, OR AS DIRECTED BY THE ENGINEER OF RECORD.

INSTALLATION NOTES

- A. ANY SUB-BASE, BACKFILL DEPTH, AND/OR ANTI-FLOTATION PROVISIONS ARE SITE-SPECIFIC DESIGN CONSIDERATIONS AND SHALL BE SPECIFIED BY ENGINEER OF RECORD.
- B. CONTRACTOR TO PROVIDE EQUIPMENT WITH SUFFICIENT LIFTING AND REACH CAPACITY TO LIFT AND SET THE STRUCTURE (LIFTING CLUTCHES PROVIDED)
- C. CONTRACTOR WILL INSTALL AND LEVEL THE STRUCTURE, SEALING THE JOINTS, LINE ENTRY AND EXIT POINTS (NON-SHRINK GROUT WITH APPROVED WATERSTOP OR FLEXIBLE BOOT)
- D. CONTRACTOR TO TAKE APPROPRIATE MEASURES TO PROTECT THE DEVICE FROM CONSTRUCTION-RELATED EROSION RUNOFF.
- E. DEVICE ACTIVATION, BY CONTRACTOR, SHALL OCCUR ONLY AFTER SITE HAS BEEN STABILIZED AND THE STORMCEPTOR UNIT IS CLEAN AND FREE OF DEBRIS.

STANDARD DETAIL NOT FOR CONSTRUCTION

SITE SPECIFIC DATA REQUIREMENTS					
STORMCEPTOR MODEL	EF4				
STRUCTURE ID	*				
WATER QUALITY FLOW RATE (L/s)	*				
PEAK FLOW RATE (L/s)	*				
RETURN PERIOD OF PEAK FLOW (yrs)	*				
DRAINAGE AREA (HA)	*				
DRAINAGE AREA IMPERVIOUSNESS (%)	*				
PIPE DATA:	I.E.	MAT'L	DIA	SLOPE %	HGL
INLET #1	*	*	*	*	*
INLET #2	*	*	*	*	*
OUTLET	*	*	*	*	*
* PER ENGINEER OF RECORD					

This design and information is provided as a service to the project owner, engineer and contractor by Imbrium Systems ("Imbrium"). Neither the drawing, nor any part thereof, may be reproduced, stored in a retrieval system, or transmitted in any form or by any means, electronic, mechanical, photocopying, recording, or by any information storage and retrieval system, without the prior written consent of Imbrium. Failure to comply with the above conditions shall constitute a breach of the license and Imbrium expressly disclaims any liability or responsibility for such use.

If discrepancies between the supplied information upon which the drawing is based and actual field conditions are discovered, the contractor shall immediately notify Imbrium in writing. Imbrium shall not be responsible for re-evaluation of the design. Imbrium accepts no liability for designs based on missing, incomplete or inaccurate information supplied by others.

MARK	DATE	REVISION DESCRIPTION	BY
###	###	INITIAL RELEASE	JSK
###	6/8/18	UPDATES	JSK
###	5/26/17		

Stormceptor® EF

imbrium

7037 RIDGE ROAD, SUITE 300, HANOVER, MD 21076
USA 888-276-8828 CA 800-588-4801 INTL +1-410-960-9600
THE ENGINEER/ARCHITECT IS PROVIDING THIS DRAWING FOR THE EXCLUSIVE USE OF THE CONTRACTOR FOR THE PROJECT IDENTIFIED HEREIN. IT IS NOT TO BE REPRODUCED, COPIED, DISTRIBUTED, OR USED FOR ANY OTHER PROJECT WITHOUT THE WRITTEN CONSENT OF IMBRIUM SYSTEMS, INC. (IMBRIUM). IMBRIUM ACCEPTS NO LIABILITY FOR DESIGN OR CONSTRUCTION ERRORS OR OMISSIONS. IMBRIUM SHALL NOT BE RESPONSIBLE FOR ANY DAMAGE TO PERSONS OR PROPERTY ARISING FROM THE USE OF THIS DRAWING.

DATE: 5/26/2017

DESIGNED: JSK	DRAWN: JSK
CHECKED: BSF	APPROVED: SP
PROJECT No.: EF4	SEQUENCE No.: *
SHEET: 1	OF 1

SCALE = NTS



ARE YOUR PONDS DRAINING YOUR MAINTENANCE BUDGET?

Most cities are finding their SWM ponds very expensive to maintain. SWM Shield™ makes inspection and maintenance more affordable - and even reduces the size of the forebay!

SWM SHIELD ADVANTAGES:

- ✓ Maintenance can be conducted by a vacuum truck, eliminating the expense and requirement of heavy equipment.
- ✓ At least doubles the time between pond dewatering maintenance.
- ✓ Reduces headaches of regulatory approvals.
- ✓ Makes inspections quick and easy.

INTRODUCING

- Pre-treatment system for LID systems
- Surface treatment solution
- Doubles LID maintenance cycles



CB SHIELD

STORMWATER TREATMENT PRODUCT PORTFOLIO



CONTACT US FOR A CONSULTATION TODAY!

519.212.9161

INFO@CBSHIELD.COM



CBSHIELD.COM

Catch basins generally provide two functions: direct water into the storm sewer and capture pollutants in the sump. However studies have found catch basin sumps never get more than a third full due to scouring, which sends captured pollutants into the receiving waters, failing their objective.

A regular catch basin (CB) performs two basic functions. A CB is great at removing storm runoff from the streets and directing it to storm sewers or green infrastructure.

The second intended function of a regular (unshielded) CB, which is capturing pollutants in the sump, it does quite poorly. Anything caught in the sump gets easily stirred up in an unshielded CB - and washed downstream (scouring).

- 1 Standard CBs are only system inlet devices and are *not very effective* for water quality.
- 2 Standard CBs are *not good at pollutant retention*.
- 3 Due to a high rate of scour, a standard unshielded catch basin is often kept clean right to the bottom of sump.
- 4 Maintenance of regular CBs doesn't result in very much sediment removed, which is a drain on resources (money as well as time).

THE CB SHIELD ADVANTAGE — HELPING WATER QUALITY:

- Costs to install and maintain a CB Shield unit are a fraction of other water quality approaches.
- CB Shield ensures scour protection so you keep what's been captured.
- In addition to scour, CB Shield also significantly outperforms a standard CB in capture of sediment.
- Can be installed in new and existing catch basins.
- Easy to install and remove for maintenance (less than one minute).
- CB Shield will not constrict even the highest flows.

During rain events, water falls directing into sump, creating turbulence and scouring out previously captured material.

HOW IT WORKS

A standard catch basin has a 1.2m waterfall of runoff pouring directly down upon it – churning up the sump below and causing a very poor rate of sediment retention. An unshielded catch basin with less than 300mm of water covering sediment will only make matters worse and increase wash-out.

The patented CB Shield™ has a sloped plate to direct runoff to the back wall of the catch basin which dissipates energy. Storm runoff then flows across a slotted grate where sediment drops through to the sump below (see illustration).

The result is a catch basin sump which remains as calm as a pond on a sunny day. The CB Shield stops sediment from being stirred up and washed downstream where cleanup costs will be much higher.

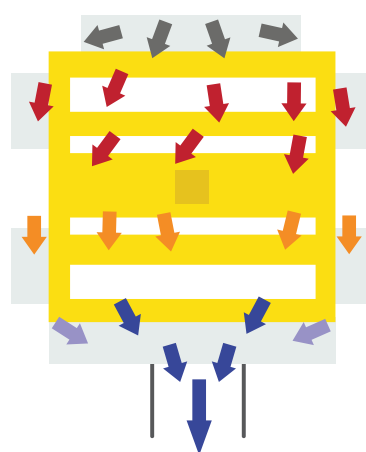

HOW DOES IT PERFORM?

Third party laboratory testing confirmed that CB Shield usage results in 92% less scouring than with non-shielded catch basins, in addition to a higher removal rate of sediment. Testing by the independent 3rd party lab had results confirmed by the Toronto and Region Conservation Authority (TRCA), resulting in CB Shield gaining

prestigious ETV Verification. Lab results translate to a predicted capture of 50% to 60% of Total Suspended Sediment (TSS) for field installations.

To demonstrate its huge increase in performance versus unshielded units, CB Shield participated in several long-term studies conducted at the University of Toronto, City of Barrie, and Region of Peel in Ontario. These are summarized:

- **U OF T** A year-long study (for a Master's thesis) indicated a CB Shield protected unit captured 47 times more sediment by mass than control CBs.
- **BARRIE** A two-year study of 20 shielded units indicated CB Shield protected catch basins had caught greater than 60% more sediment and 70% more total phosphorous than nearby unshielded 'control' catch basins.
- **PEEL** An ongoing study on a 6-lane collector road indicated CB Shield protected CBs continued to capture significant sediment while unprotected CBs (under completely identical catchment conditions) were scoured clean.

The chart below indicates results of third-party scour testing using ETV PSD, completed with a catch basin sump height at 150mm, with and without the CB Shield device in place. The CB Shield provided significant protection against scouring.

Flow Rate (L/s)	Average Sediment Concentration of Effluent (mg/L) at given Flow Rate					Total Mass Scoured for Entire Test (kg)
	1.2	4.8	8.4	12.0	15.6	
CB SHIELD	9.0	2.0	8.0	80.0	193	1.5
Unshielded	258	6187	5413	1332	322	34.7

PRODUCTS

Available in single, double catch basin, side inlet or catch basin manhole configurations, CB Shield has a solution that's easily adaptable to suit any build situation. For pond maintenance, our innovative SWM Shield (detailed on the following page) has the results you're looking for! Contact us to see how we can save you time, money and increase performance on your stormwater installations.

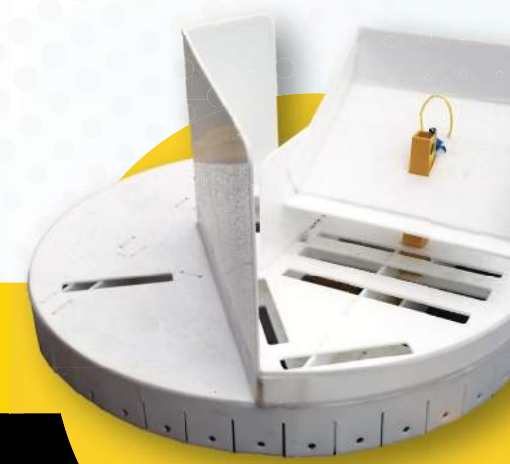
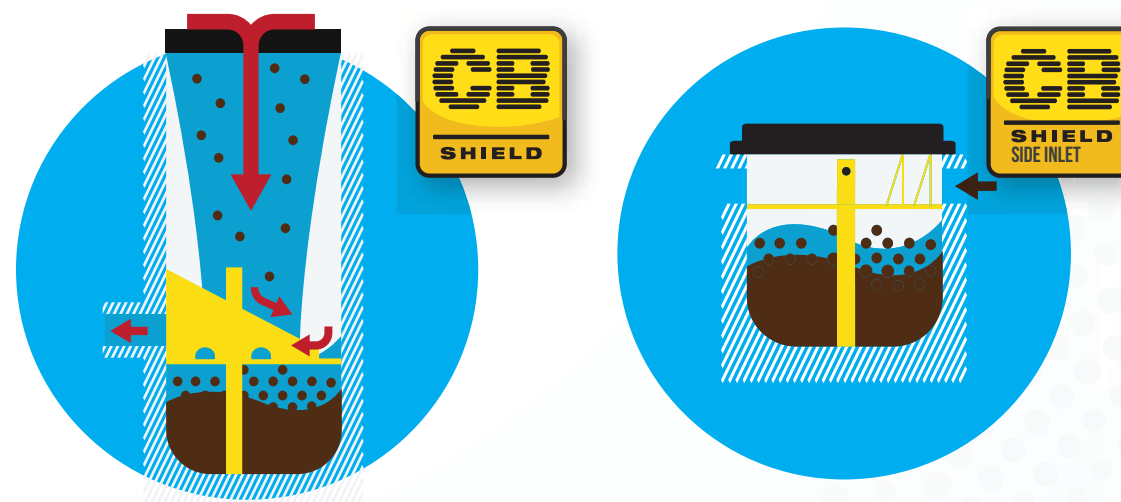

NEW! CBMH FOR MANHOLE INSTALLATIONS

APPENDIX 'D' – City Infrastructure Drawings

70-S-154 – Limeridge Road West Plan & Profile

70_S-162_7 – Neighbourhood Sanitary Drainage Area Plan

70-S-162_5 – Neighbourhood Storm Drainage Area Plan

LIMERIDGE RD

SEWERS

154

S

70

LIMERIDGE ROAD

ST. JEROMES SEPARATE SCHOOL

CERTIFICATE OF COMPLETION

THIS CERTIFIES THAT THE WORK SHOWN ON THIS DRAWING HAS BEEN COMPLETED AS INDICATED WITH ALL VARIATIONS AND CORRECTIONS SHOWN IN GREEN.

DATE _____ RESIDENT ENGINEER _____

NOTE

SEWER AS CONSTRUCTED - SHOWN IN GREEN
CONSTRUCTED BY - DON.RAY.
DATE COMPLETED - NOVEMBER-27-1970.
INSPECTOR - G.SMITH.
KIND OF PIPE -
TYPE OF GROUND - CLAY.
PLOTTED BY - PAUL SCHILTE.

LIMERIDGE RD.
(THIS PORTION OF ROAD TO BE CLOSED)

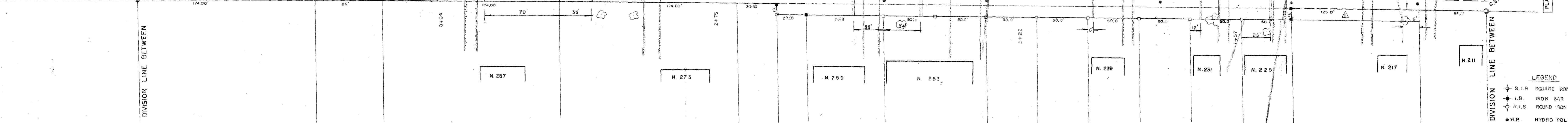

NOTE:
-TOP OF CONCRETE CHIMNEY TO BE 15" BELOW FUT. RD. GR.
-MANHOLE COVERS TO BE SET FLUSH WITH RESTORED ROAD SURFACE, AND HAVE ENOUGH BRICKS ON CHIMNEY TO MAKE FUT. FINAL ADJUSTMENT POSSIBLE.
-DRAINAGE DITCHES ARE TO BE DIVERTED TO THE PROP. CATCH BASINS.

LEGEND
S.I.B. SQUARE IRON BAR
I.B. IRON BAR
R.I.B. ROUND IRON BAR
H.P. HYDRO POLE
B.H. BOREHOLE
NOTE:
BELL ARMED CABLE ON POLES ON SOUTH SIDE OF STREET.

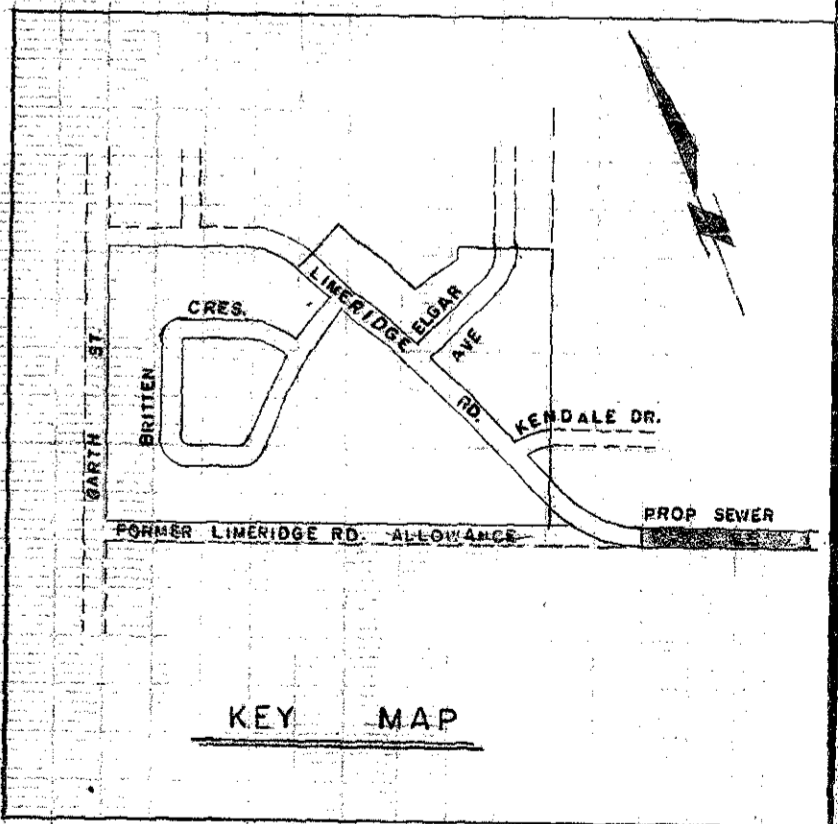
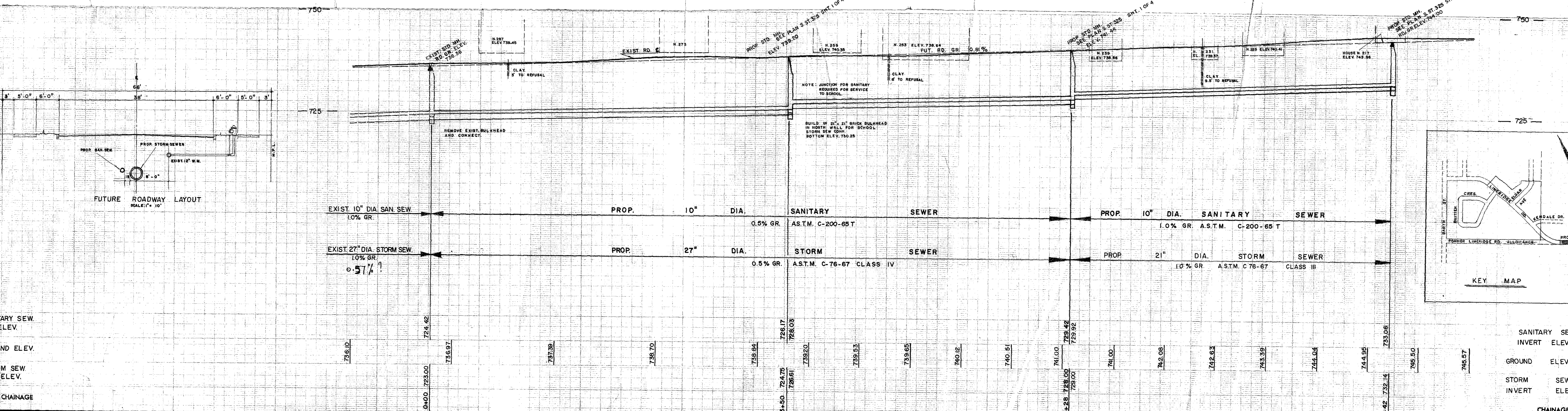

NOTES: TENDERERS SHALL SATISFY THEMSELVES AS TO THE NATURE OF THE GROUND AND BID ACCORDINGLY.
ALL ROCK LINE INDICATIONS SHOWN ON THE PROFILE MUST BE VERIFIED BY THE CONTRACTOR.
CITY INSPECTOR TO CHECK OFFICE COPY PRIOR TO CONSTRUCTION FOR DATA.

SCALE: 1" = 10' 1" = 40' VERTICAL HORIZONTAL	REVISIONS: ROAD ALLOW. WIDE. BY 10' MUNICIPAL NO 217 (I.O.) UTILITIES: 4B	REF. DWG'S: SEW. L 129 SURV. B-371 W.W. 241	SURVEY BY: Plant FIELD BOOKS: B-15 DATE: Feb 70 BENCH MARK: CITY OF HAMILTON GEODETIC B.M. N°167 ELEV.739.530	DRAWN BY: P. L. Angelici CHECKED BY: [Signature] ASST. DIRECTOR, ENGRG. DESIGN. DIRECTOR, ENGRG. DESIGN.	APPROVED: [Signature] CITY ENGINEER AND MANAGER OF WATER WORKS	CITY OF HAMILTON DEPARTMENT OF ENGINEERING DESIGN SECTION PROJECT No. ES-70-1 ACCOUNT No. 0408-30072	LIMERIDGE ROAD FROM 625' SOUTHERLY AND EASTERLY OF KENDALE DRIVE (FUT. STREET) TO 342' EASTERLY. DRAWING No. 70 - S - 154 SHEET 1 OF 1
--	--	--	--	---	---	--	---

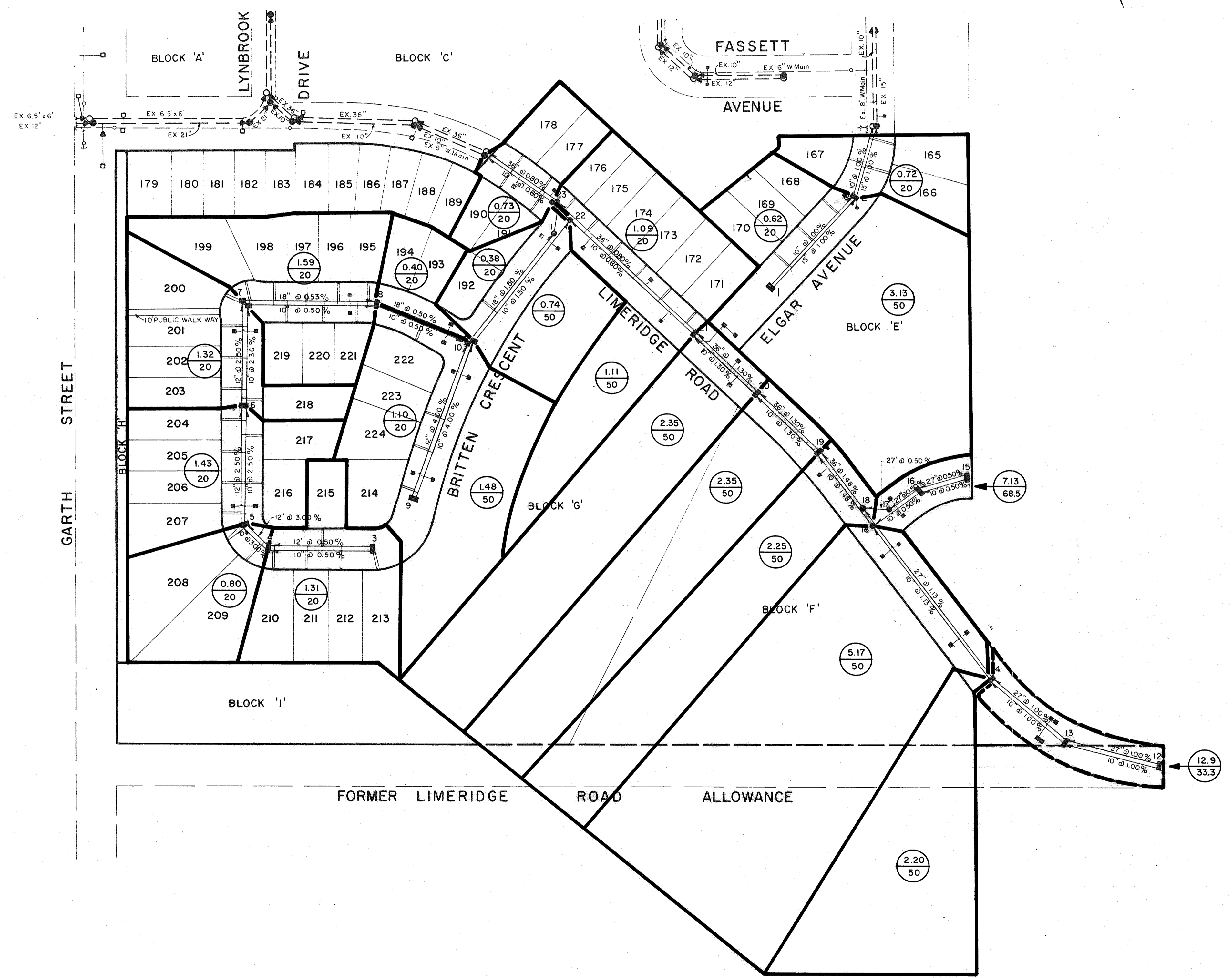
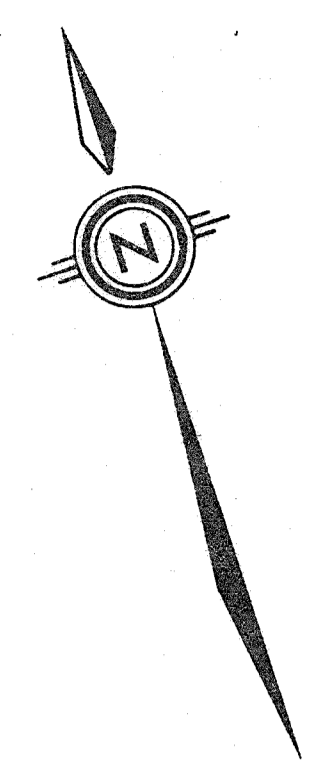

LEGEND:

1.31 / 20 ACREAGE
 POPULATION DENSITY

B.M. N° 167 ELEV. 739.630 (GEODETIC)
 TABLET IN TOP OF CONCRETE MONUMENT, NORTH SIDE
 OF LIMERIDGE ROAD, 0.2 MILE EAST OF GARTH STREET,
 200 FEET WEST OF PROPERTY LINE.

CITY OF HAMILTON			
FEDERAL PROVINCIAL LAND ASSEMBLY PROJECT			
ROLSTON NEIGHBOURHOOD BELLWOOD ORCHARDS STAGE II			
SANITARY DESIGN AREA PLAN			
WYLLIE & UFNAL LIMITED			
CONSULTING ENGINEERS		TORONTO	
SCALE	VERT. HORIZ.	DATE: AUGUST, 1969	
DESIGN	B.N.		
DRAWN	F.B. & M.F.H.	Dwg. No. S3-255-4	

70-5-162 (7/7)

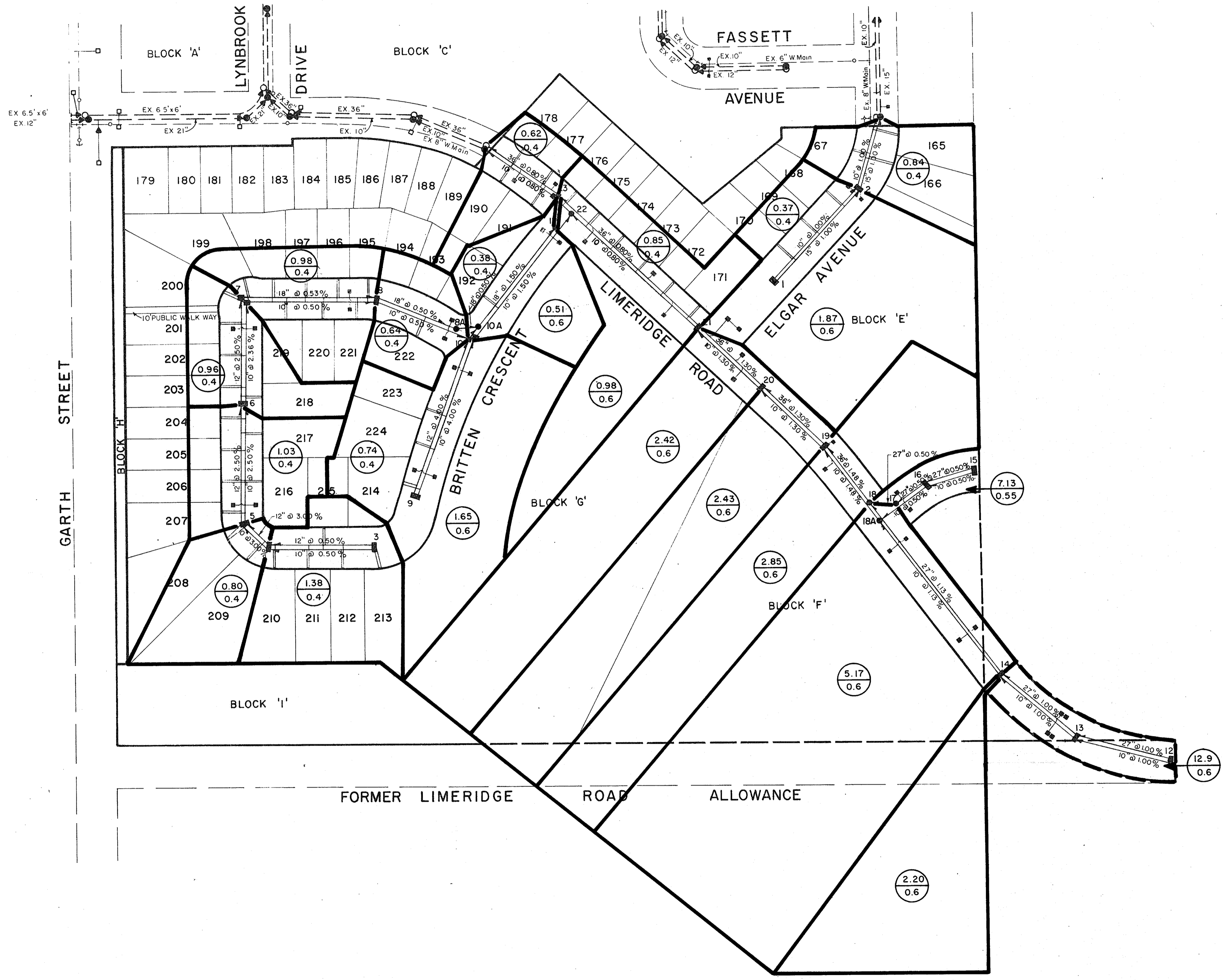
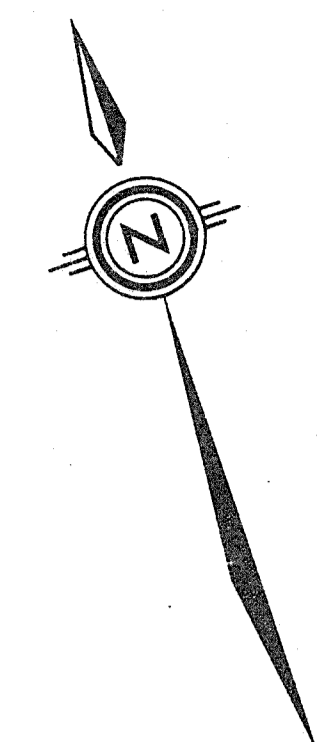

LEGEND :

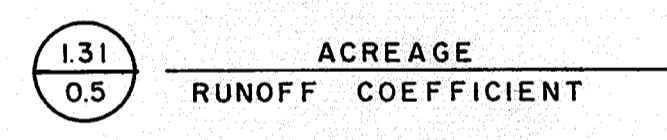

B.M. N° 167 ELEV. 739.630 (GEODETIC)
 TABLET IN TOP OF CONCRETE MONUMENT, NORTH SIDE OF
 LIMERIDGE ROAD, 0.2 MILE EAST OF GARTH STREET,
 200 FEET WEST OF PROPERTY LINE.

CITY OF HAMILTON			
FEDERAL PROVINCIAL LAND ASSEMBLY PROJECT			
ROLSTON NEIGHBOURHOOD BELLWOOD ORCHARDS STAGE II			
STORM DESIGN AREA PLAN			
WYLLIE & UFNAL LIMITED CONSULTING ENGINEERS TORONTO			
SCALE	VERT.	HORIZ.	DATE: AUGUST, 1969.
		1" = 100'	
DESIGN	B. N.		Dwg. No. S3-255-3
DRAWN	F.B. & M.F.H.		

70-5-162 (2)